

52582

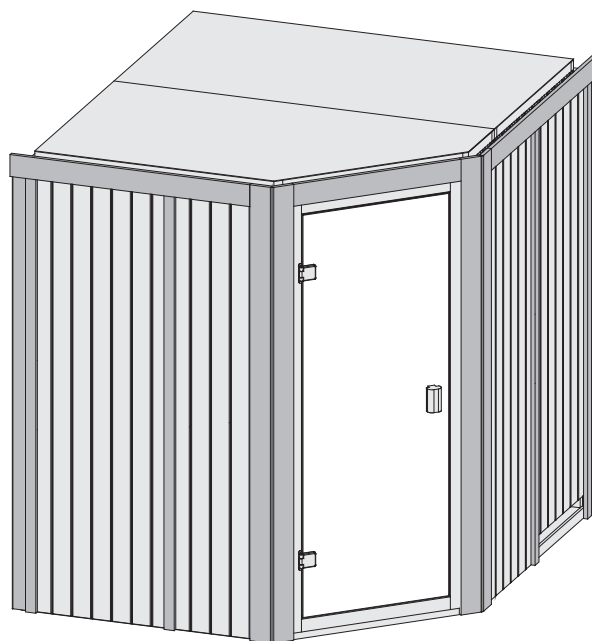

-  **Aufbauanleitung**
-  **Building Instructions**
-  **notice de montage**
-  **montagehandleiding**
-  **Montagevejledning**
-  **Instrucciones de construcción**
-  **Istruzioni per il montaggio**
-  **Montážní návod**

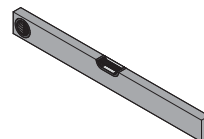

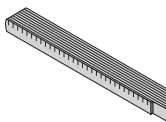
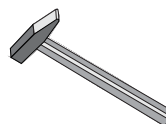
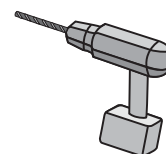
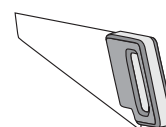

Vergleichen Sie zuerst die Material-liste mit Ihrem Paketinhalt! Bitte haben Sie Verständnis, dass Beanstandungen nur im nicht aufgebauten Zustand bearbeitet werden können!



Vergelijk eerst de lijst van materialen met de inhoud van uw pakket! Reclamaties kunnen alleen in behandeling worden genomen zolang de onderdelen nog niet zijn gemonteerd!



Confrontate questa distinta materiali prima con il contenuto del pacchetto! Vi preghiamo di comprendere che eventuali reclami possono essere accolti solo prima del montaggio!



First compare the list of materials with your package contents! Please understand that complaints can be processed in the non-built status only!



Start med at kontrollere materialelisten med indholdet af den leverede pakke! Vi gør venligst opmærksom på at reklamationer kun kan behandles for materialer som ikke er blevet bearbejdet!



Nejprve přezkontrolujte obsah balení podle materiálového listu! Mějte pochopení pro to, že případnou reklamaci se můžeme zabývat pouze tehdy, když díly nebudou smontované! Za pomoci tohoto seznamu můžete jednotlivé díly přiřadit k montážnímu návodu.



Commencez par comparer la liste du matériel avec le contenu de votre paquet! Sachez que nous traitons uniquement les réclamations concernant le matériel à l'état non monté!



En primer lugar, compare la lista de material con el contenido del paquete. Rogamos entienda que las reclamaciones sólo pueden ser tramitadas antes de montar el objeto!

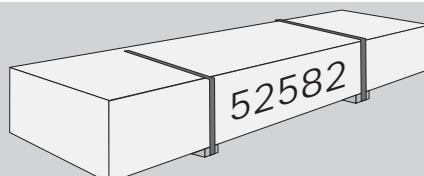

1 x W1	1920 x 433 x 68mm	ID 25547
2 x W2	1920 x 606 x 68mm	ID 25548

1 x W3	1920 x 606 x 68mm	ID 25550

1 x W4	1920 x 433 x 57mm	ID 23623
4 x W5	1920 x 606 x 57mm	ID 23624

1 x W6	1920 x 606 x 57mm	ID 23629

1 x T1	1872 x 780 x 42mm	ID 25551

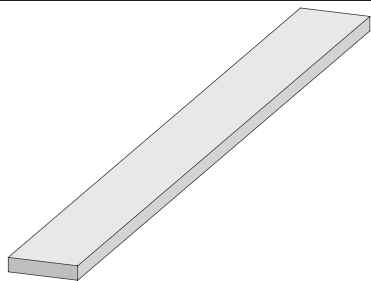

10 x B1	1920 x 19 x 3mm	ID 20799
4 x B2	70 x 45 x 18mm	ID 26366
6 x B3	800 x 45 x 18mm	ID 24796
4 x B4	1884 x 45 x 18mm	ID 48037
4 x B5	480 x 95 x 18mm	ID 20930
4 x B6	580 x 95 x 18mm	ID 16708
1 x B7	765 x 95 x 18mm	ID 26357
1 x B8	1050 x 95 x 18mm	ID 25761
1 x B9	1227 x 95 x 18mm	ID 26379
1 x B10	300 x 120 x 18mm	ID 22467
2 x B11	550 x 42 x 28mm	ID 24053
2 x B12	900 x 42 x 28mm	ID 25866
1 x B13	1641 x 42 x 28mm	ID 52515
2 x B14	1750 x 42 x 28mm	ID 52514
1 x B15	1759 x 42 x 28mm	ID 24133
2 x B16	1841 x 42 x 28mm	ID 26376
3 x B17	1874 x 52 x 52mm	ID 26165

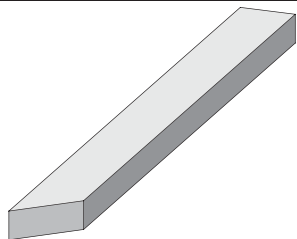

1 x C1	1020 x 42 x 28mm	ID 52524
2 x C2	1117 x 42 x 28mm	ID 52517
1 x C3	1178 x 42 x 28mm	ID 25867
2 x C4	1247 x 42 x 28mm	ID 25740

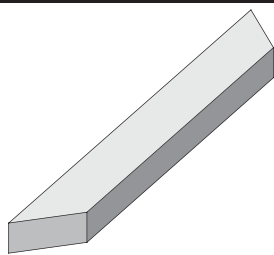

1 x D1	859 x 42 x 28mm	ID 24114
2 x D2	896 x 42 x 28mm	ID 24110

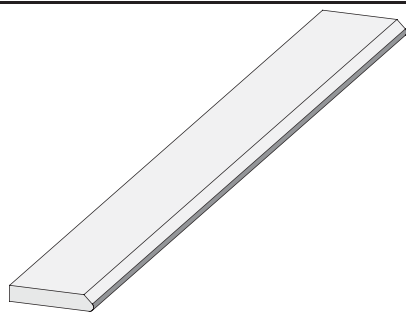

2 x G1	1884 x 58 x 17mm	ID 48521
4 x G2	1980 x 95 x 17mm	ID 48540

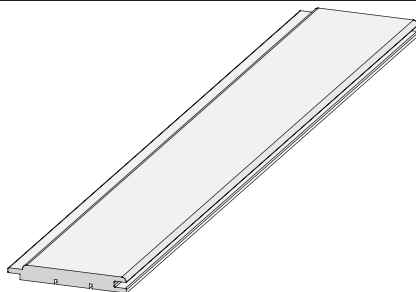

2 x E1	1920 x 97 x 12mm	ID 22863
--------	------------------	----------

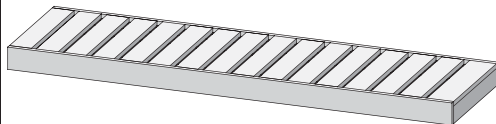

2 x L1	1810 x 550 x 90mm	ID 52616
--------	-------------------	----------

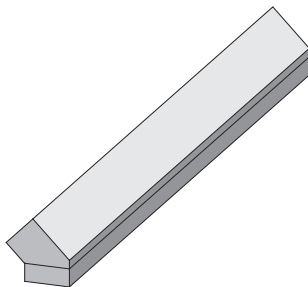

2 x K1	1874 x 76 x 38mm	ID 43464
--------	------------------	----------

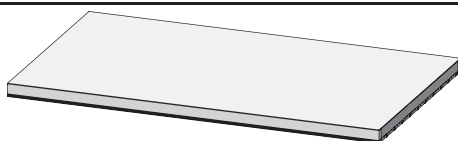

1 x M1	1665 x 918 x 57mm	ID 52518
--------	-------------------	----------

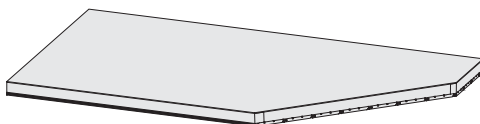

1 x M2	1665 x 918 x 57mm	ID 52516
--------	-------------------	----------

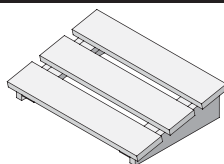

1 x		ID 20708
-----	--	----------

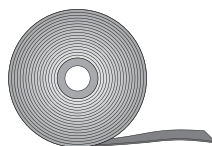

10m		ID 14025
-----	--	----------

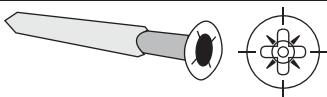

80 x	4,5 x 40mm	ID 26285
------	------------	----------

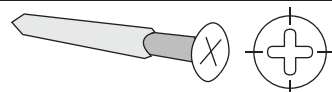

50 x	4 x 35mm	ID 3687
60 x	4 x 50mm	ID 3688
50 x	4 x 70mm	ID 3689
50 x	4,5 x 80mm	ID 9204
15 x	6 x 60mm	ID 14014

6 x S1		ID 14266
--------	--	----------



150 x S2	4,5 x 30mm	ID 26116
16 x S3	12 x 18mm	ID 46403

20 x		ID 14005
------	--	----------

2 x		ID 26496
-----	--	----------

1 x		ID 26183
-----	--	----------



6 x	3 x 16mm	ID 46376
-----	----------	----------

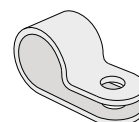

1 x		ID 50420
-----	--	----------

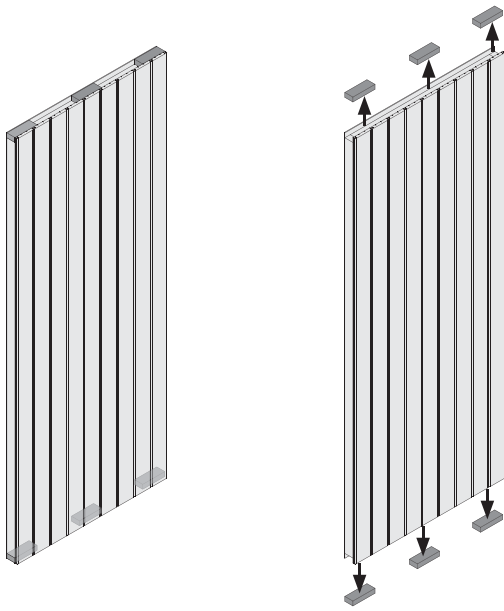

-  Vorsicht!
-  Attention!
-  Attention!
-  Voorzichtig!
-  Forsigtig!
-  Cuidado!
-  Occhio!
-  Pozor!

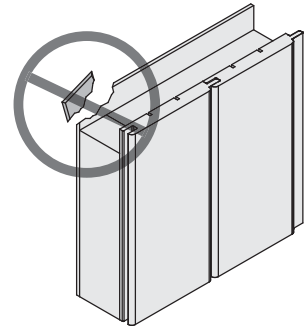

01

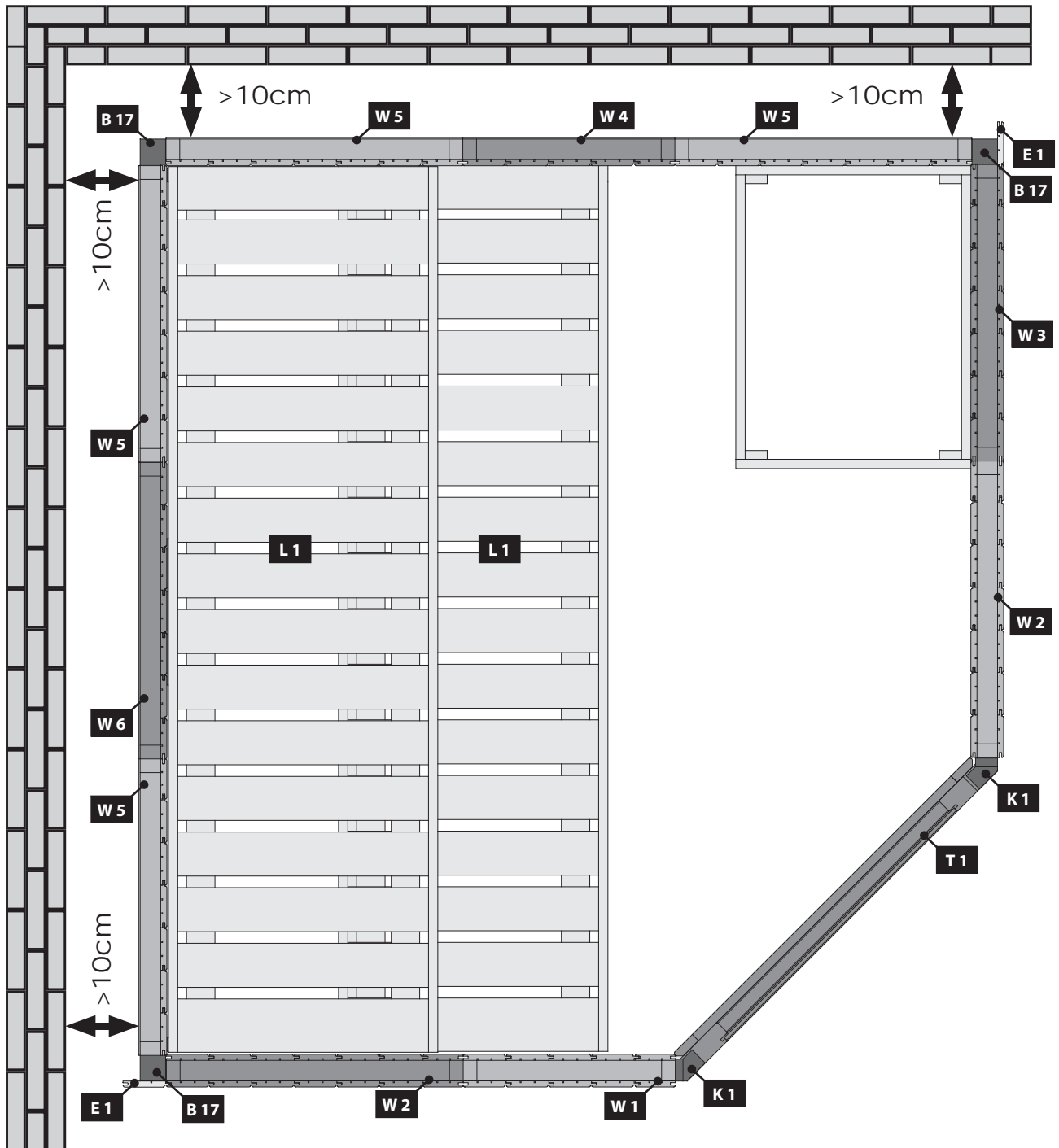

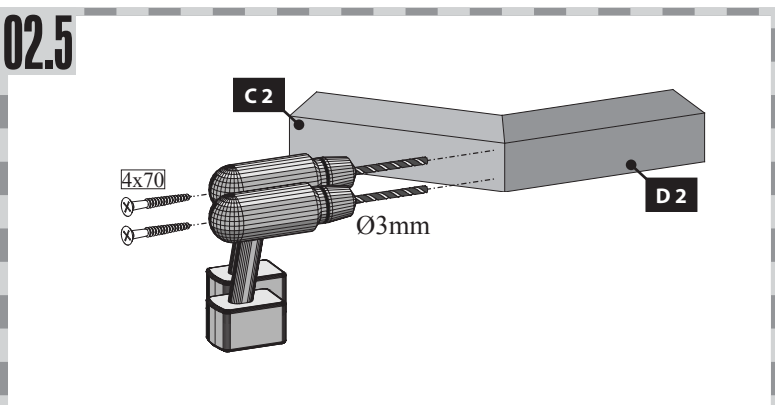
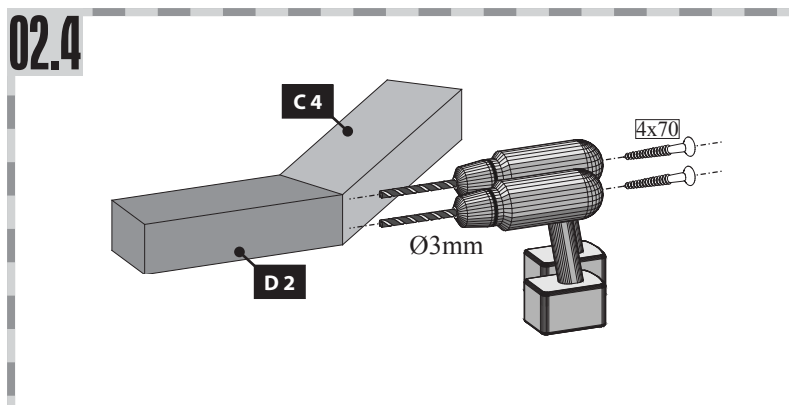
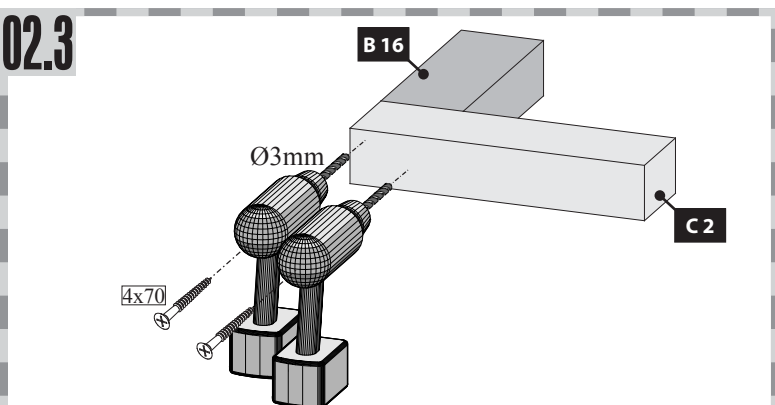
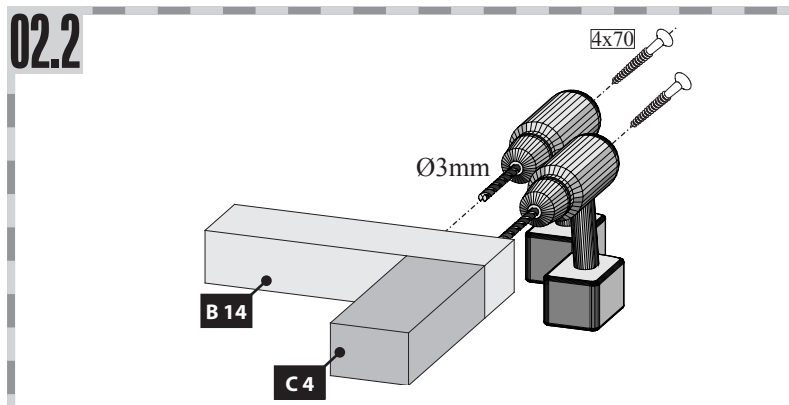
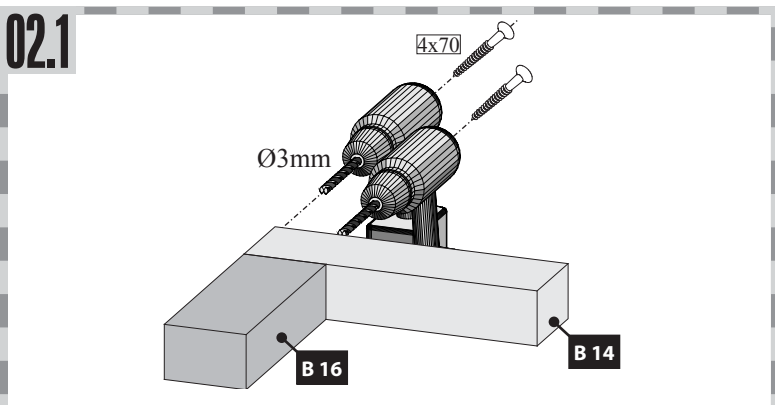
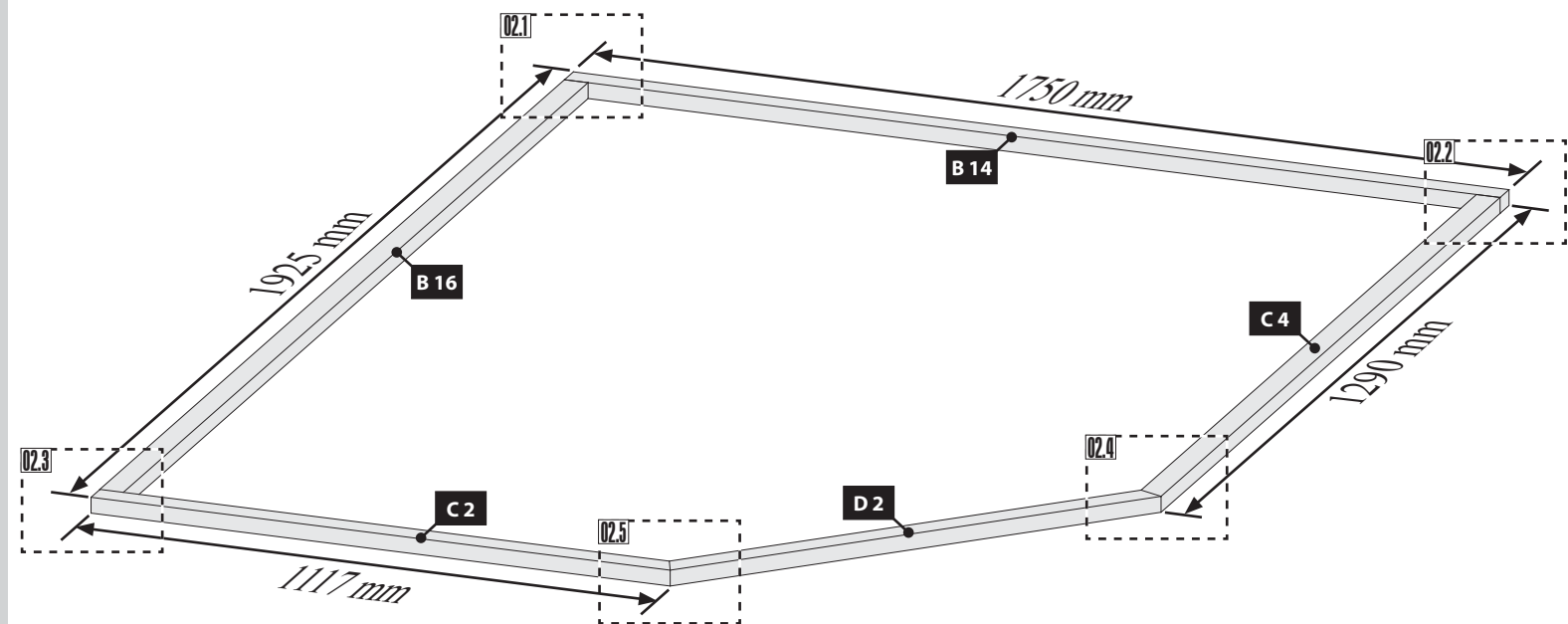

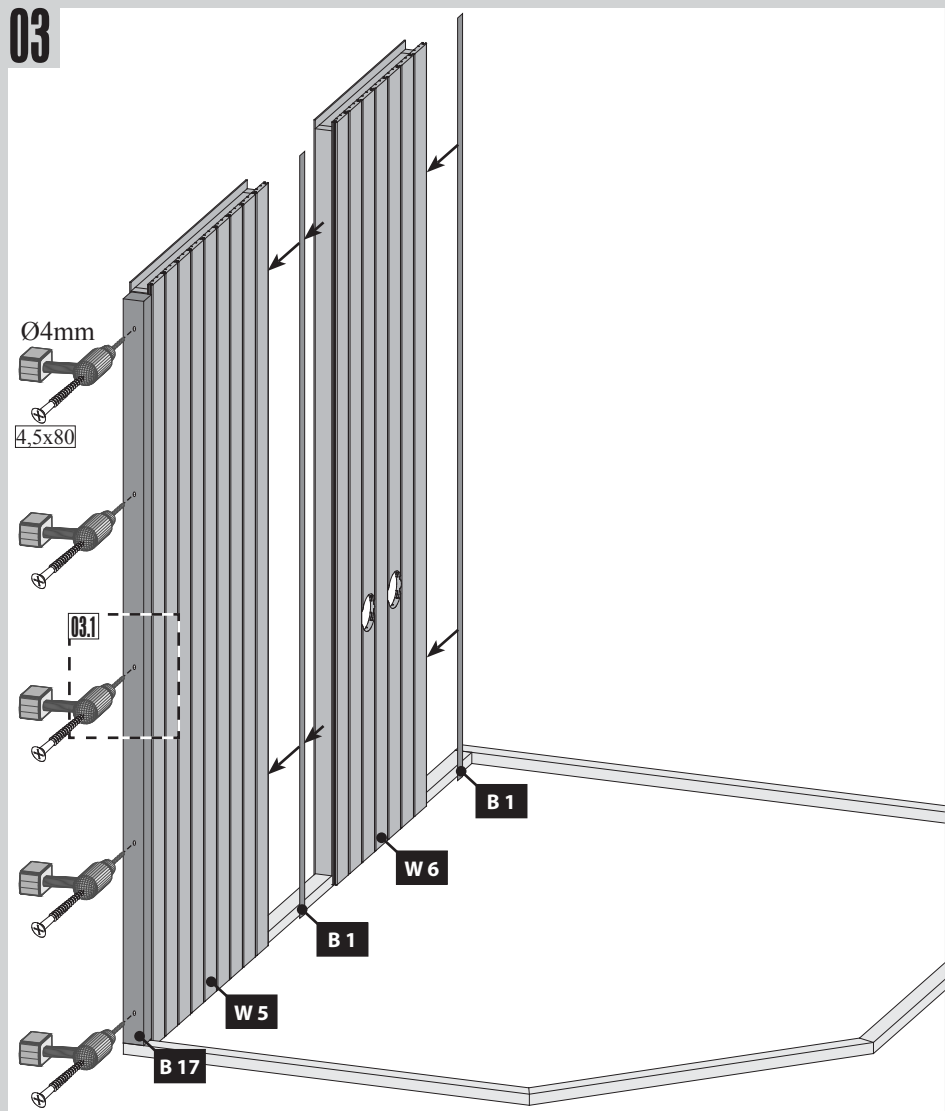
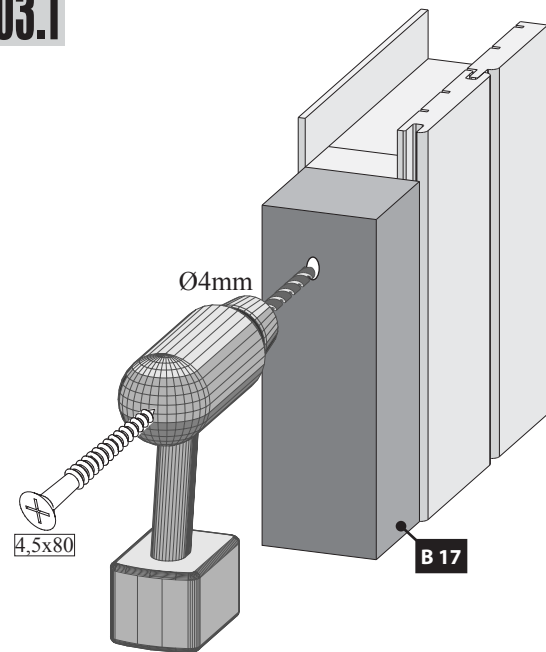
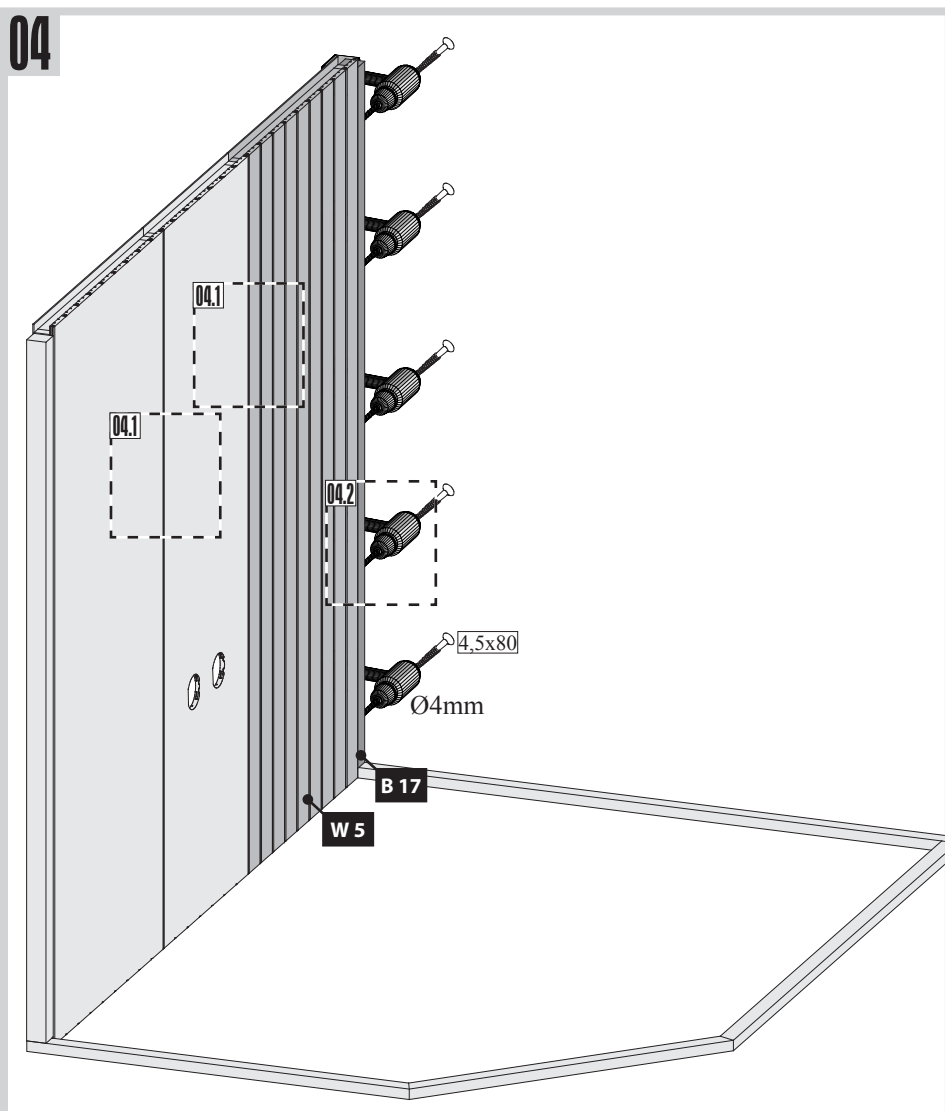
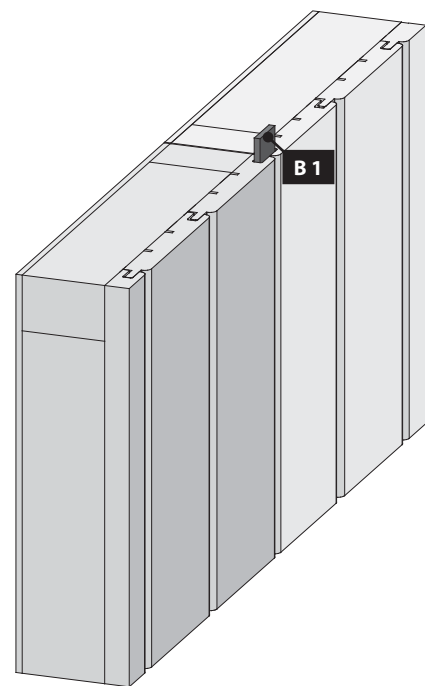
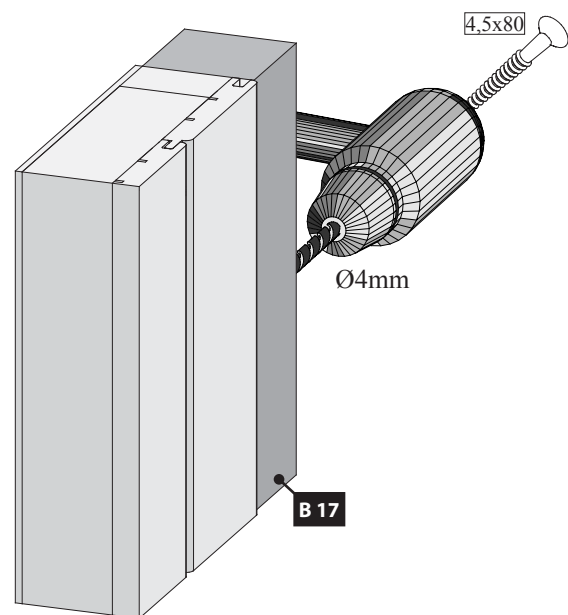
03**03.1****04****04.1****04.2**

05

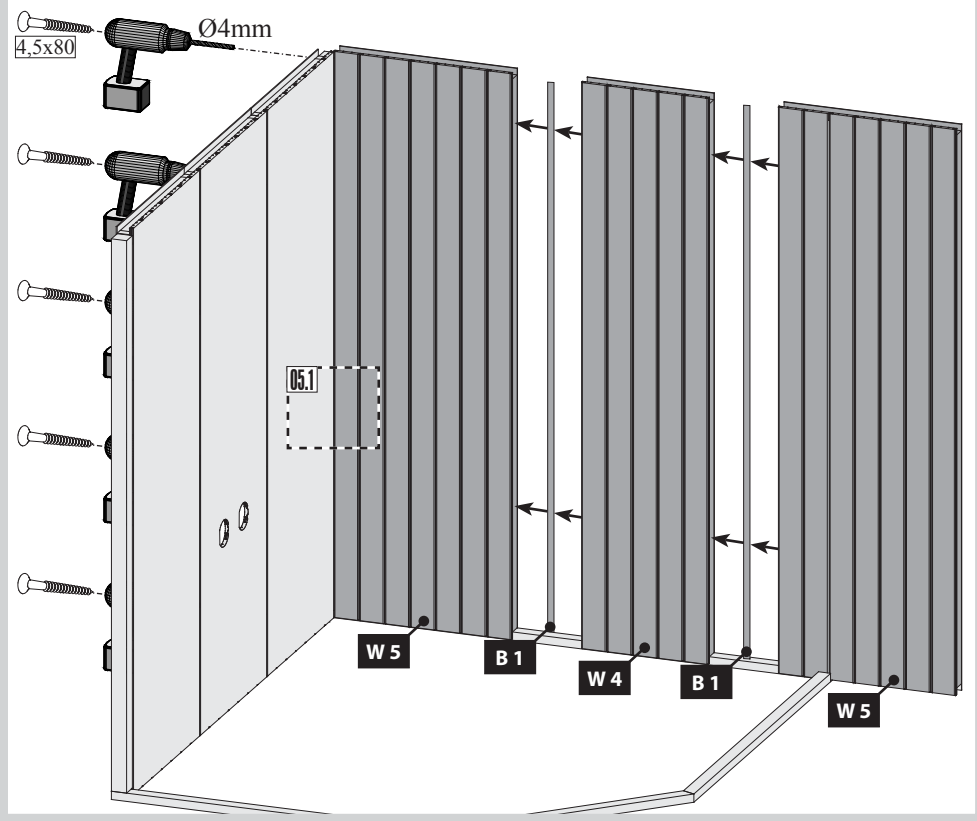

05.1

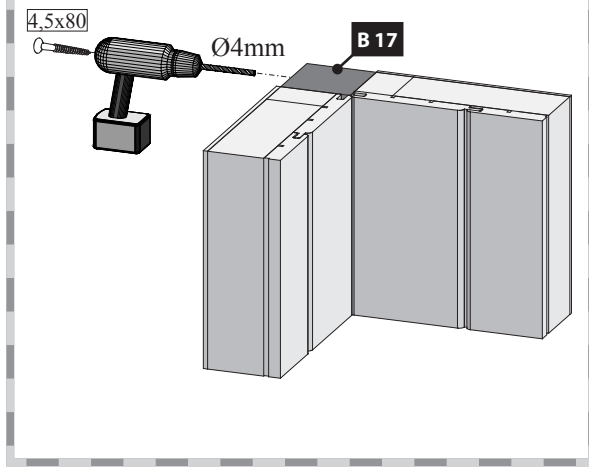

06

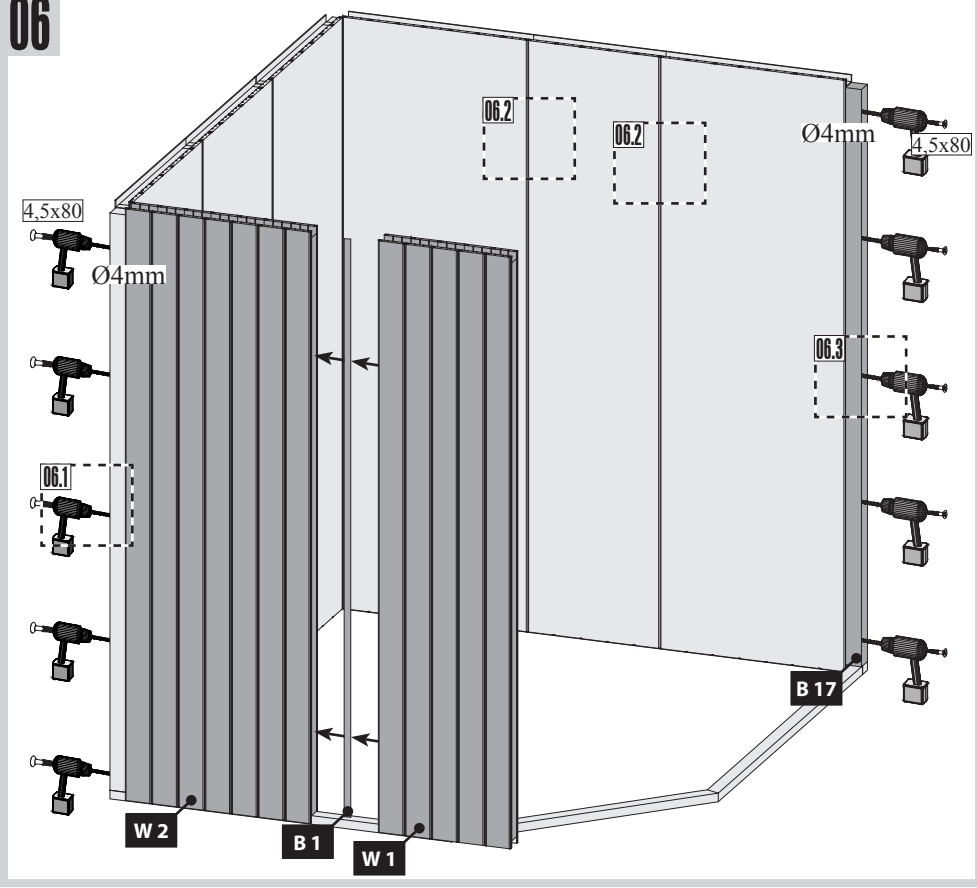

06.1

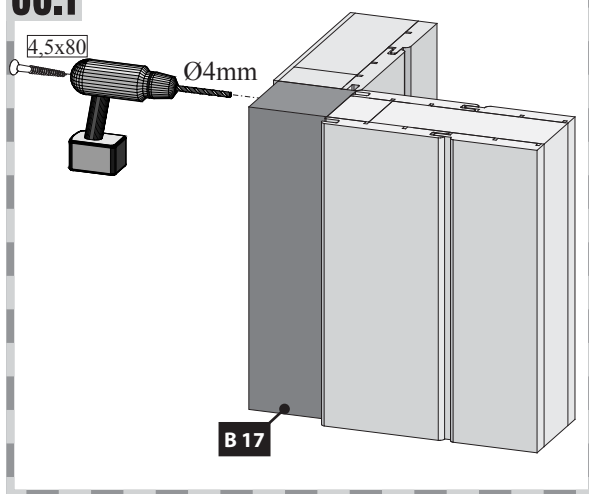

06.2

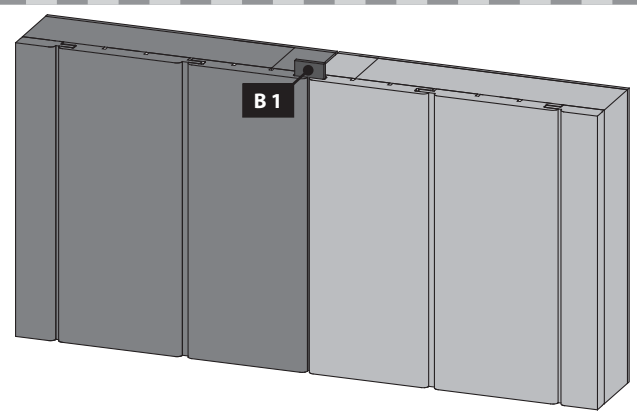

06.3

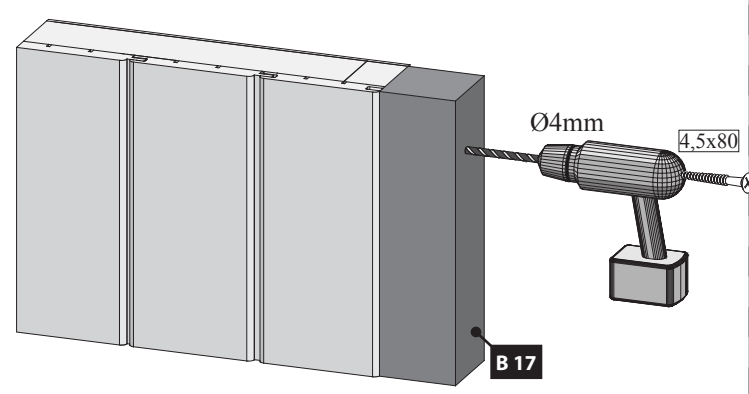

07

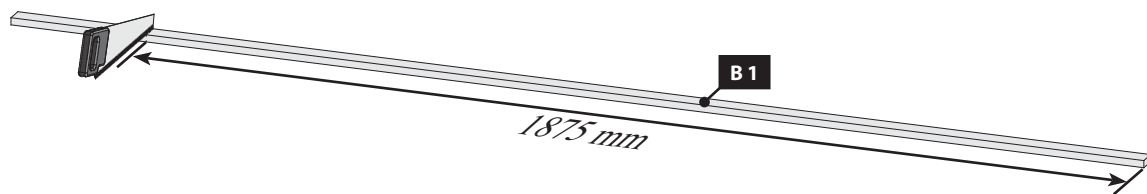

08

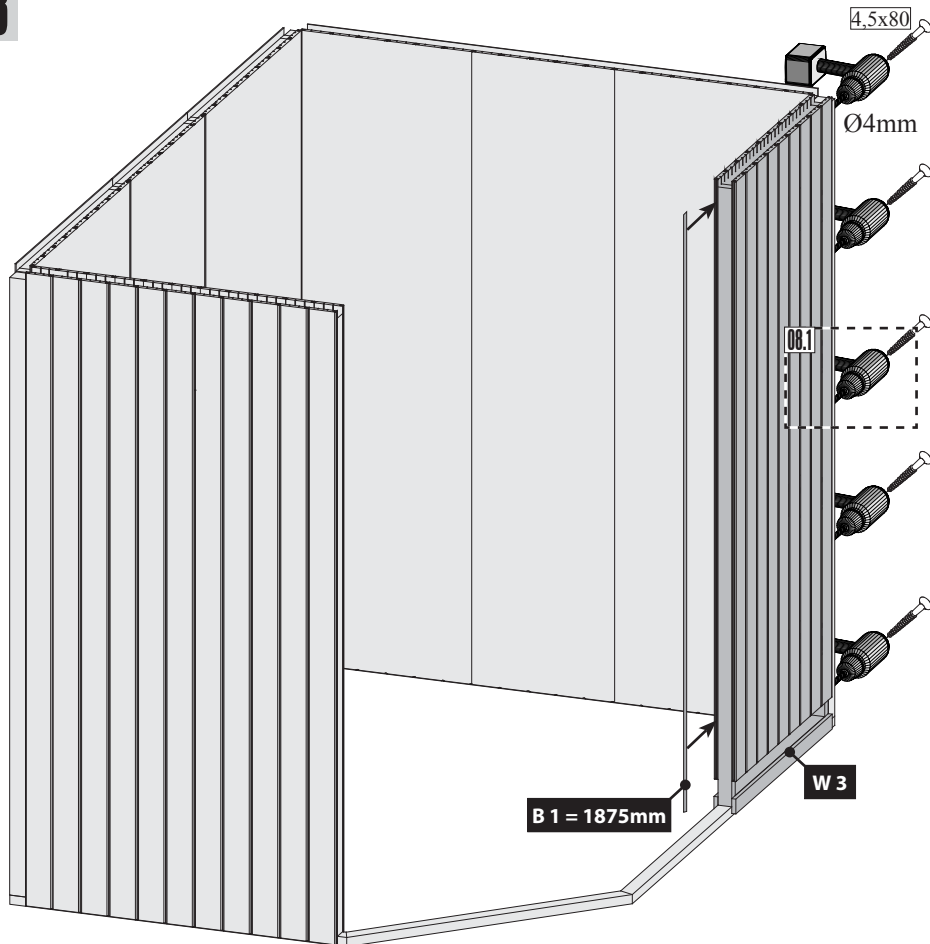

08.1

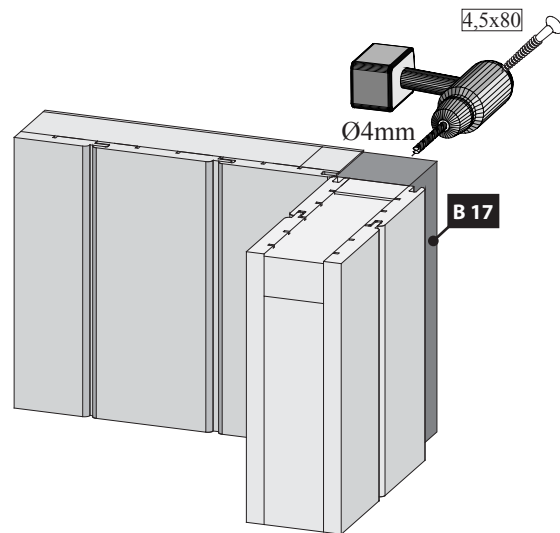

09

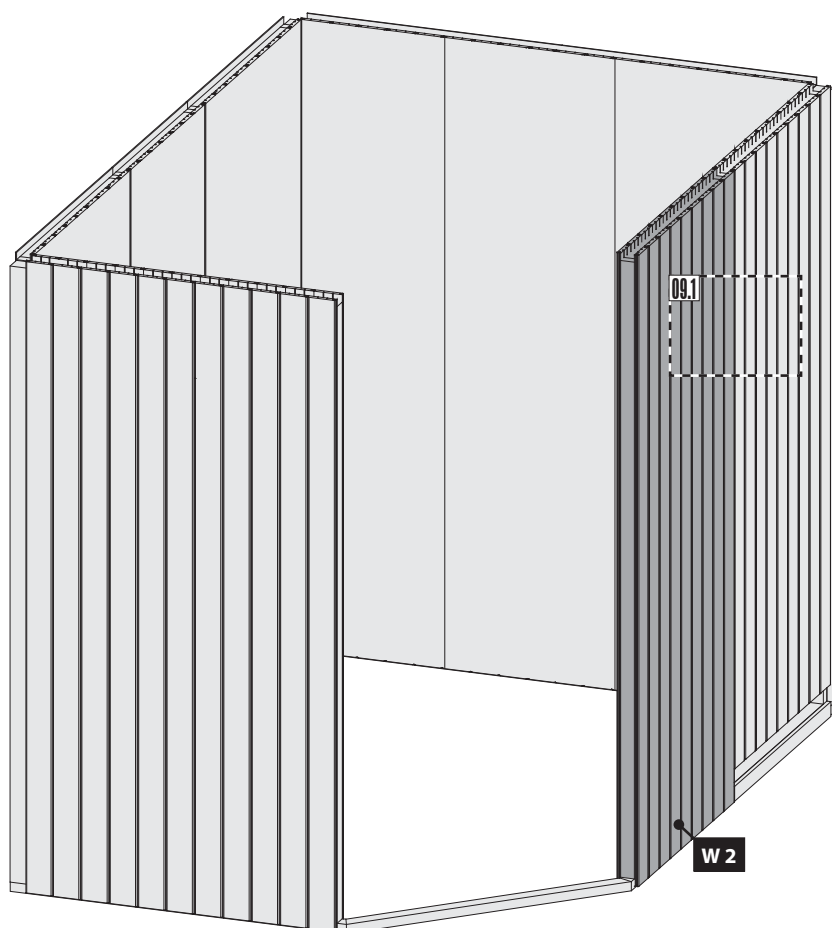

09.1

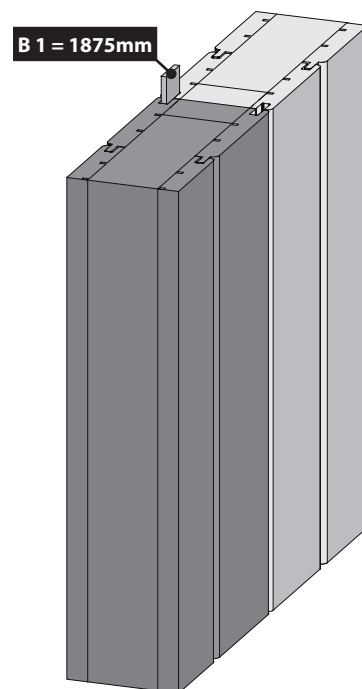

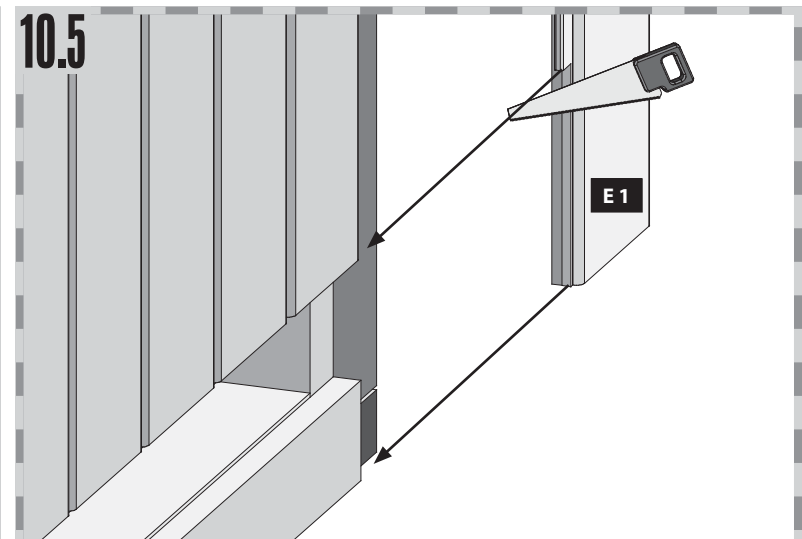
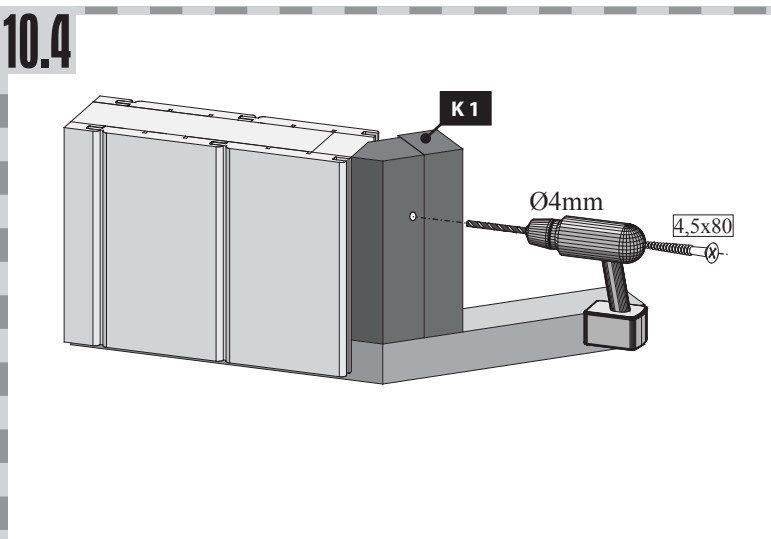
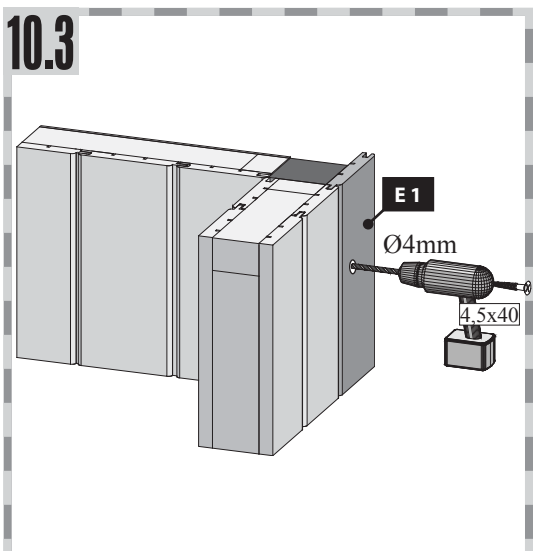
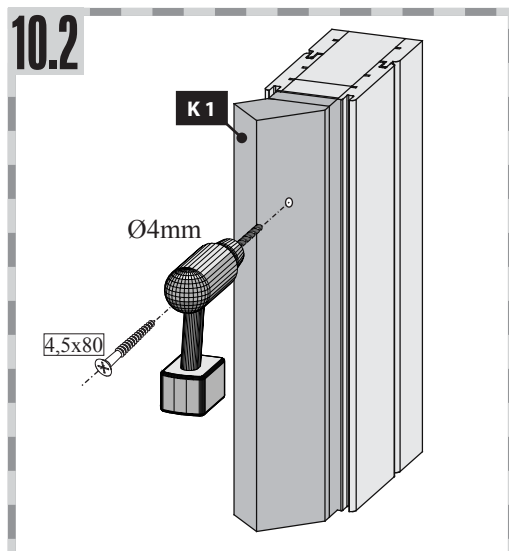
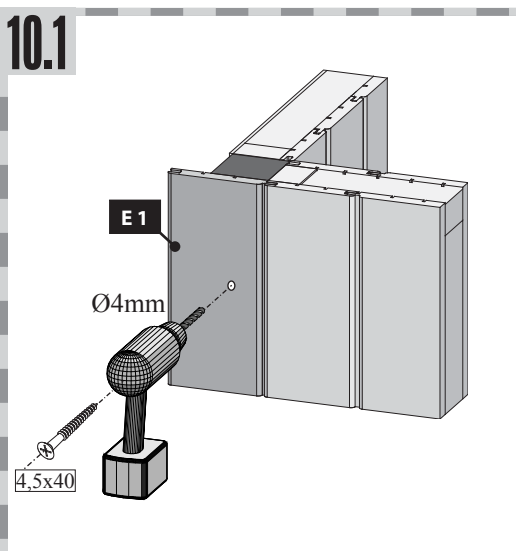



 Einbau Glastür

 Montage porte en verre

 Installation of glass door

 Montage van de glazen deur

 Montaje de la puerta de cristal

 Installazione portello di vetro

11.1

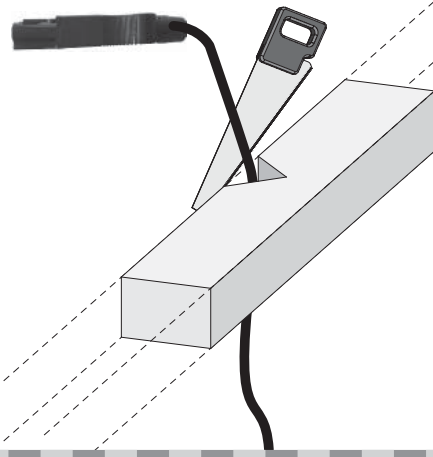

01 — 03



11

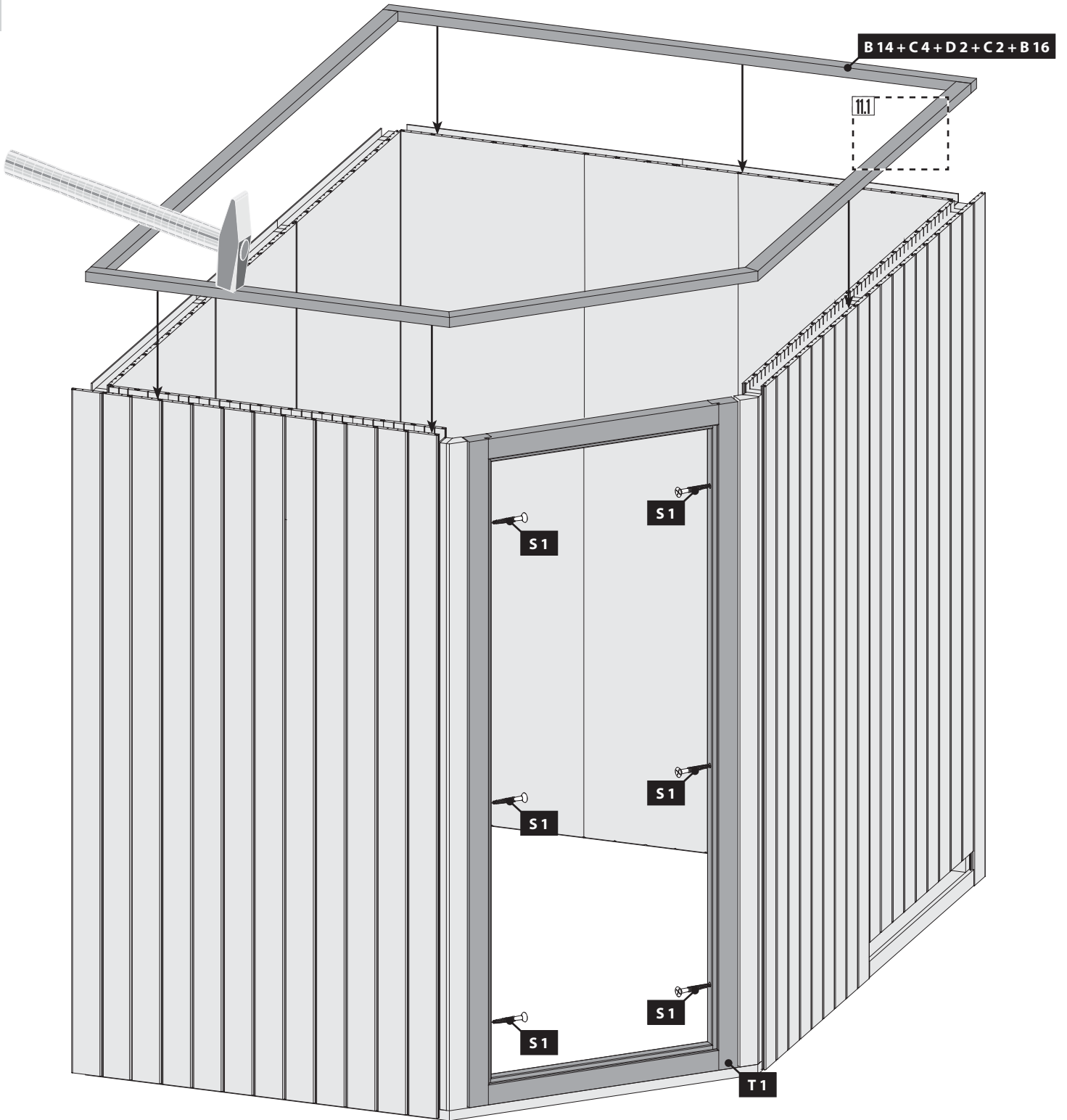

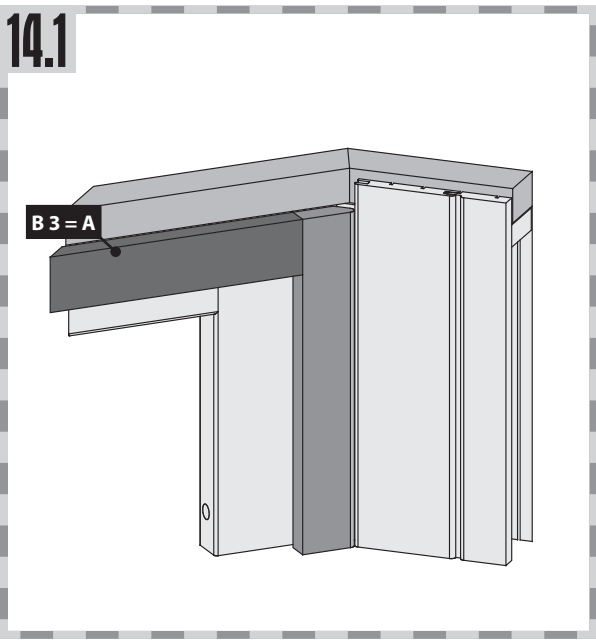
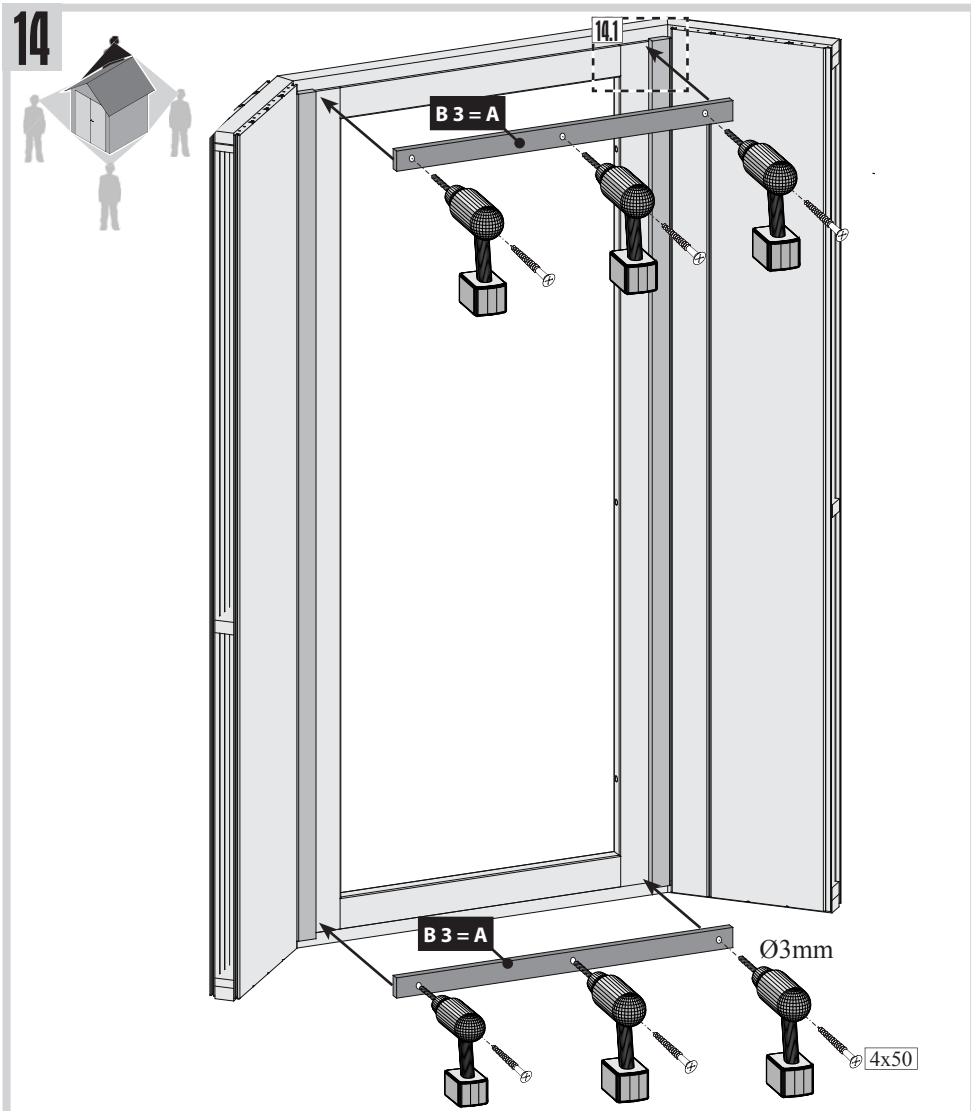
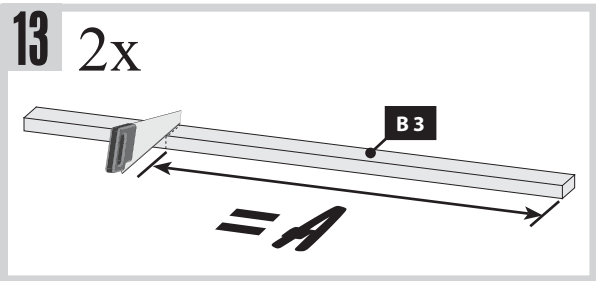
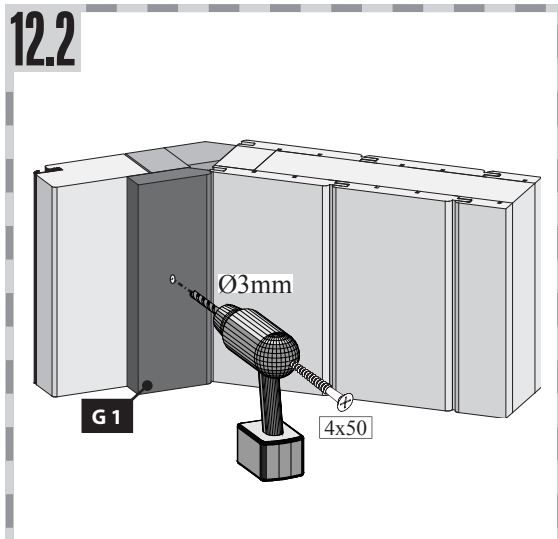
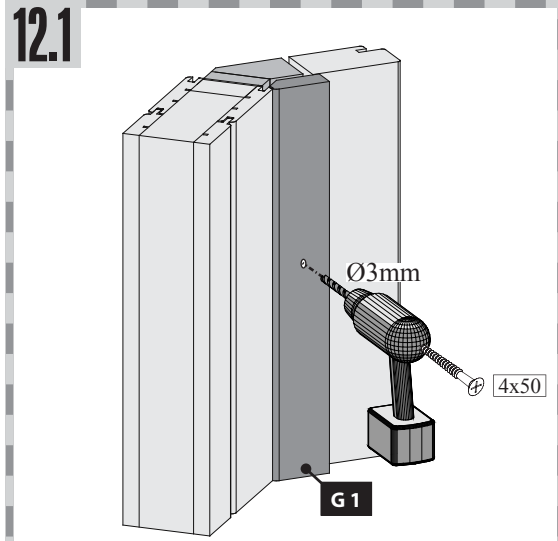
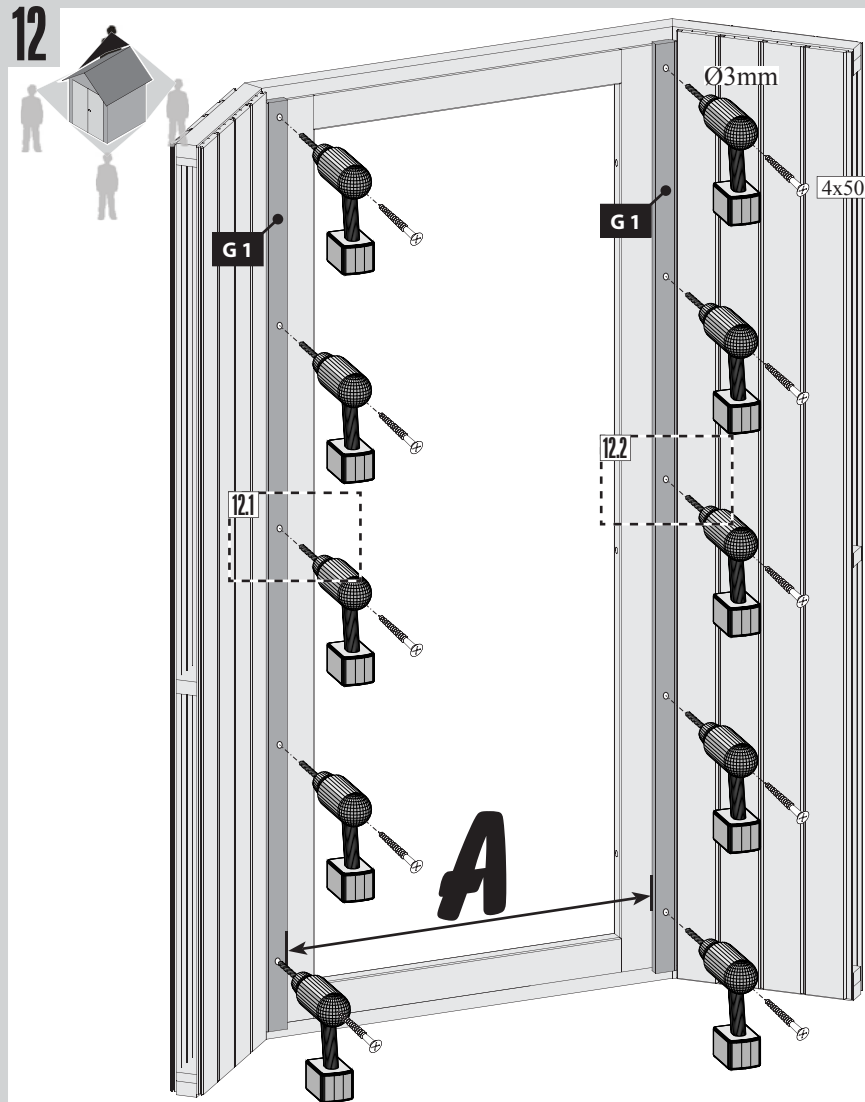

15

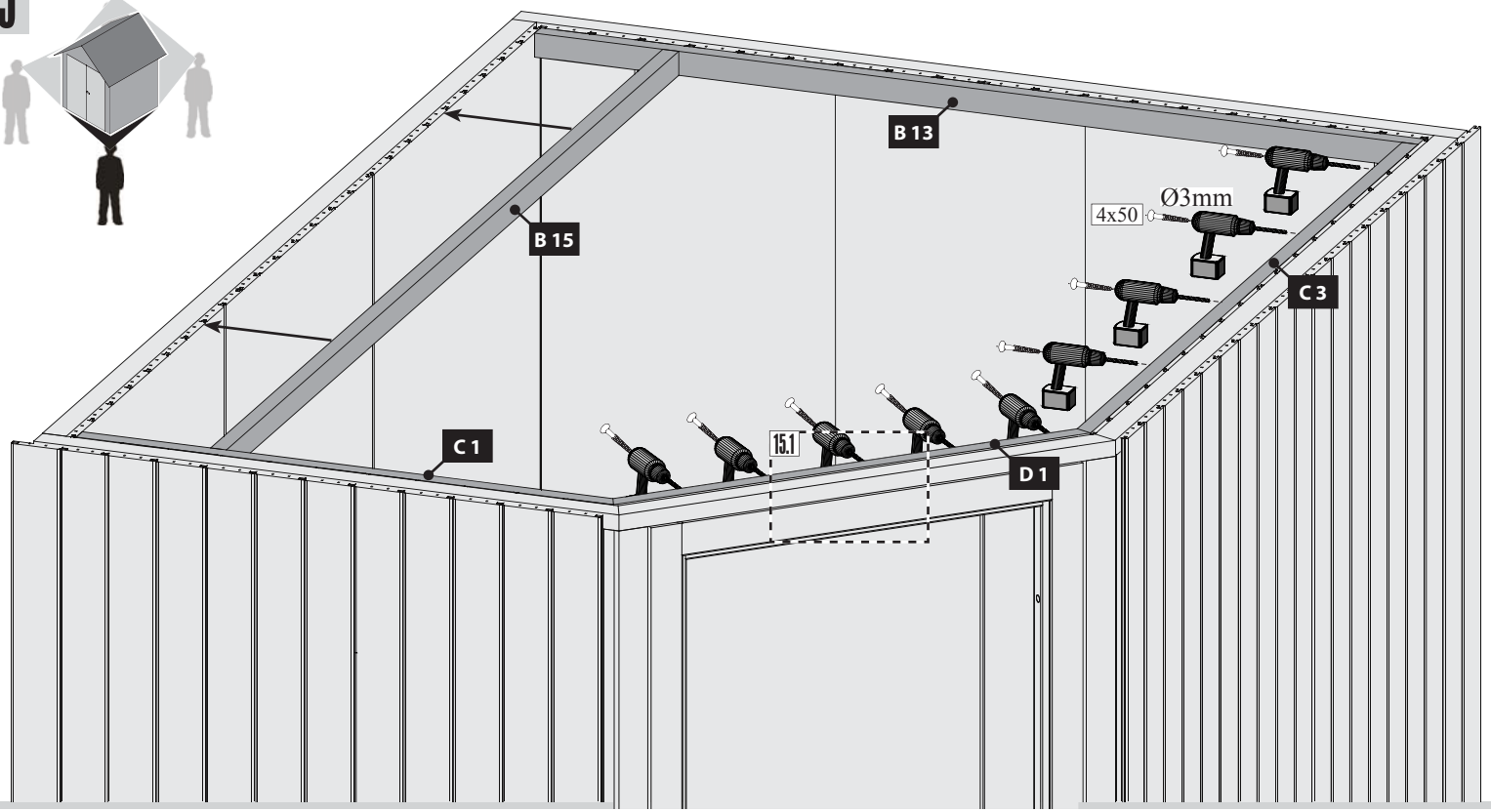
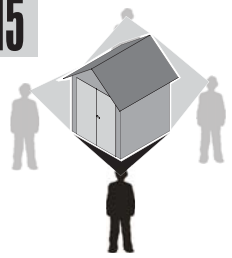

16

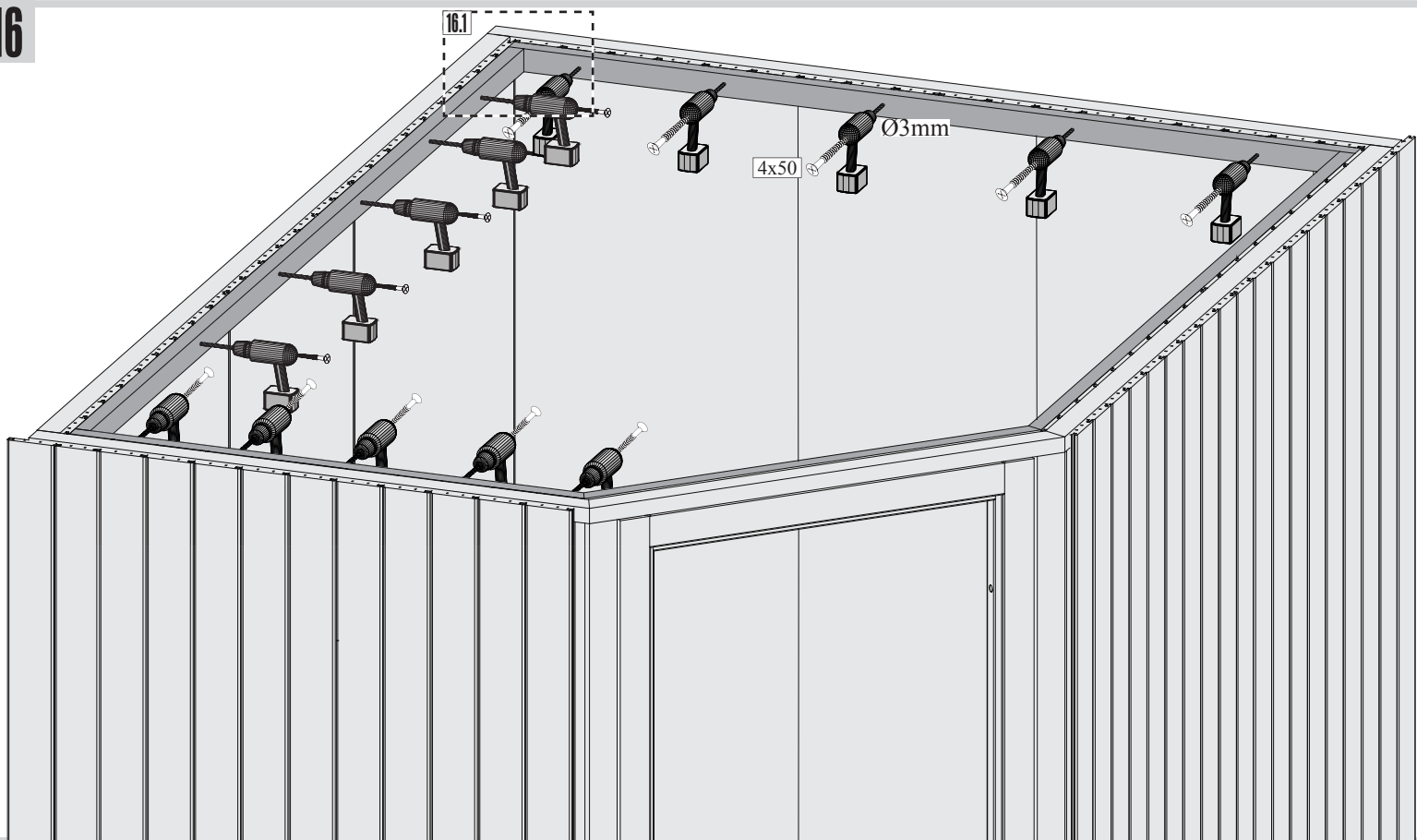

15.1

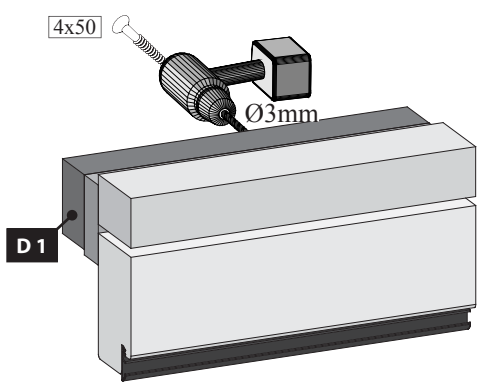

16.1

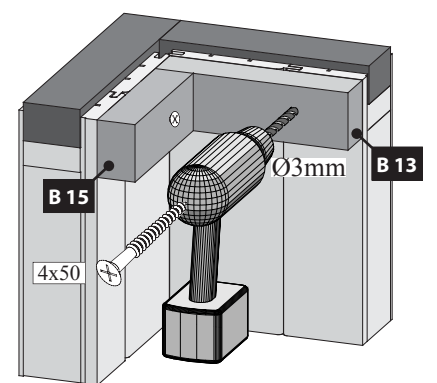

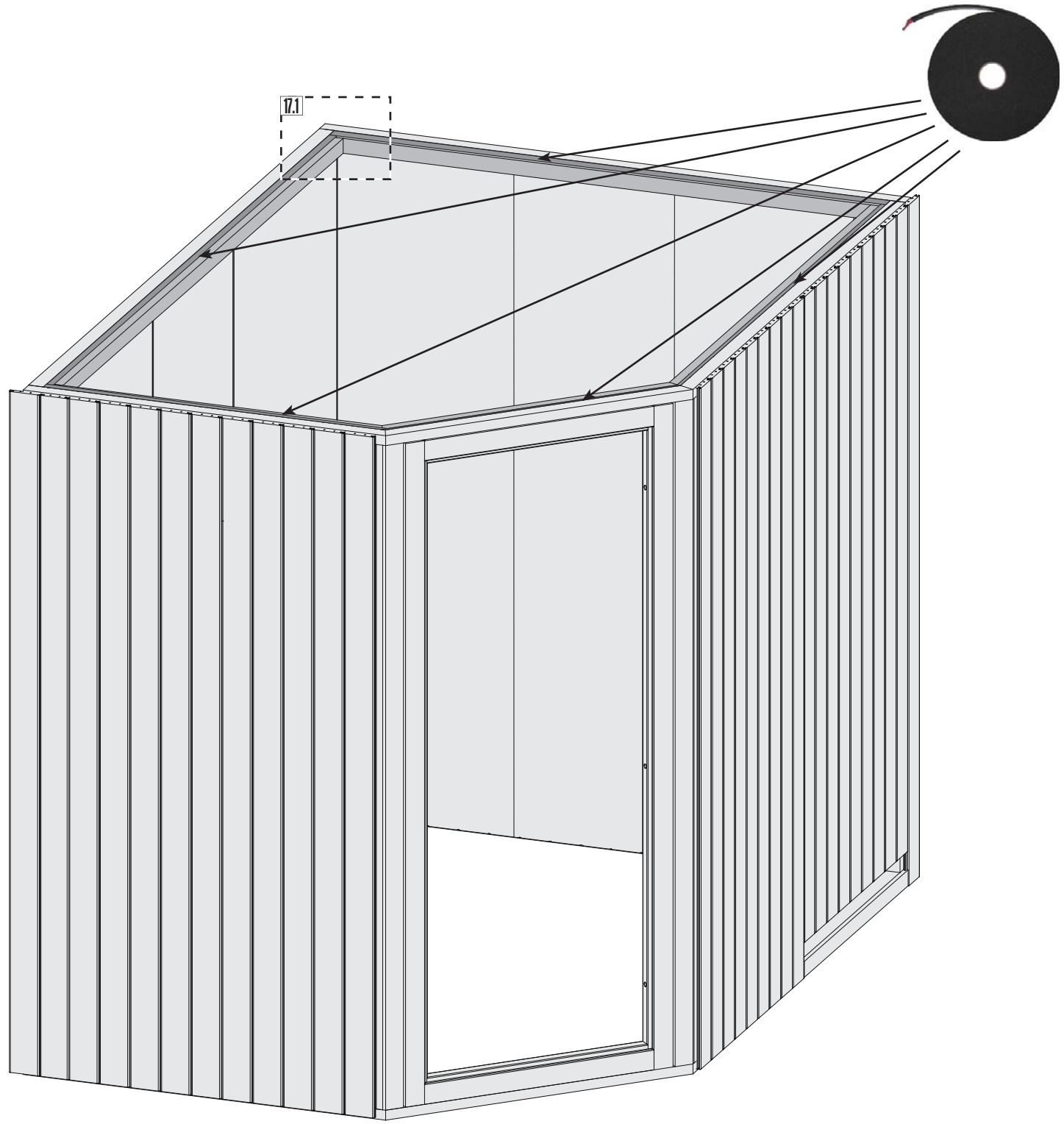

17.1

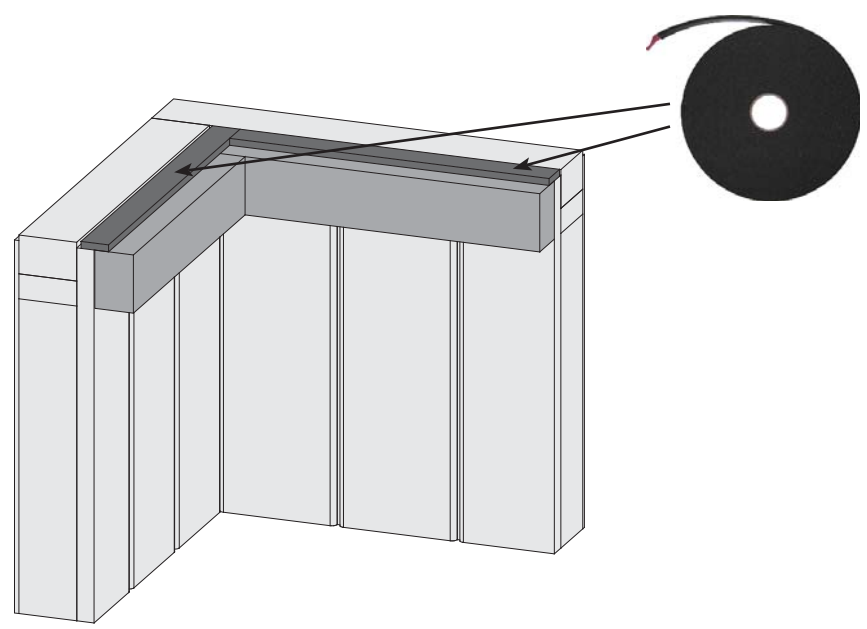

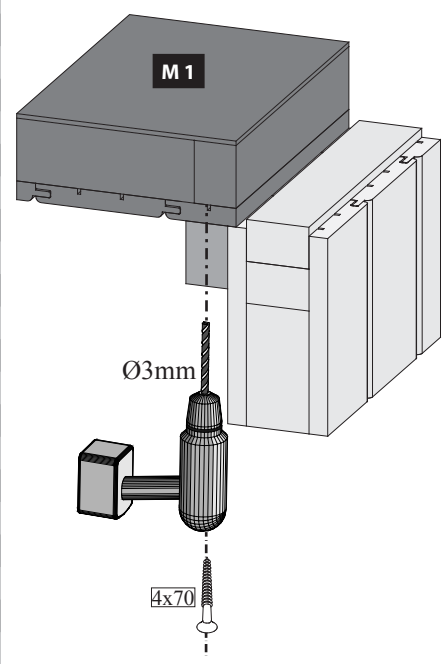
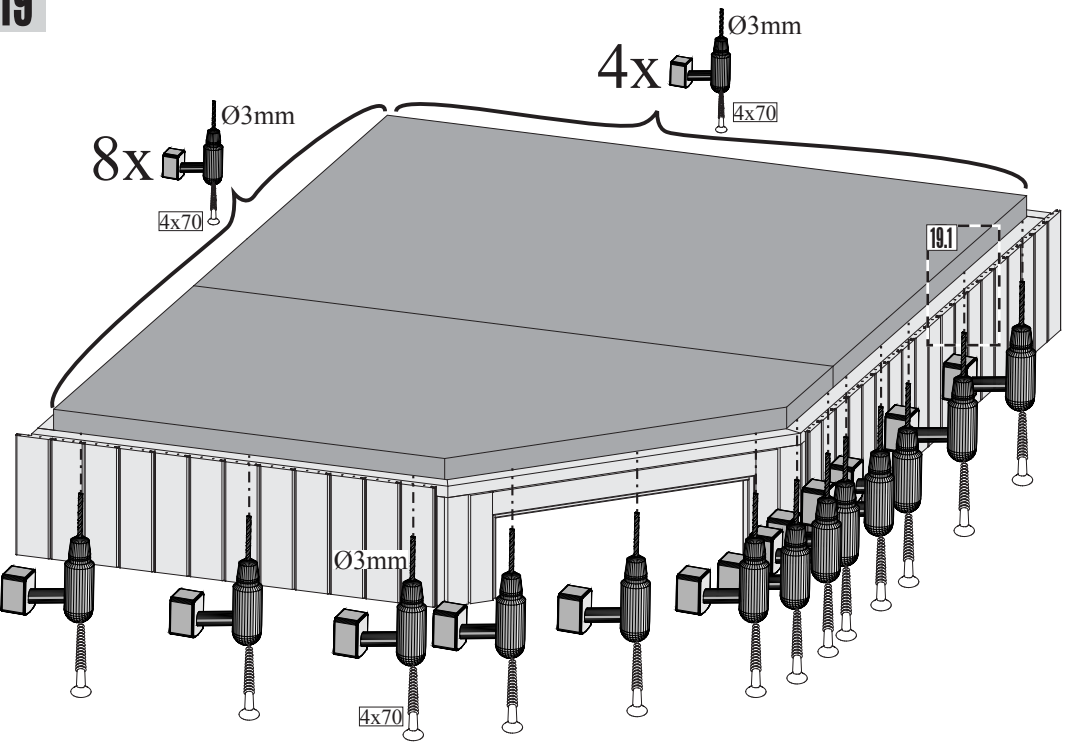
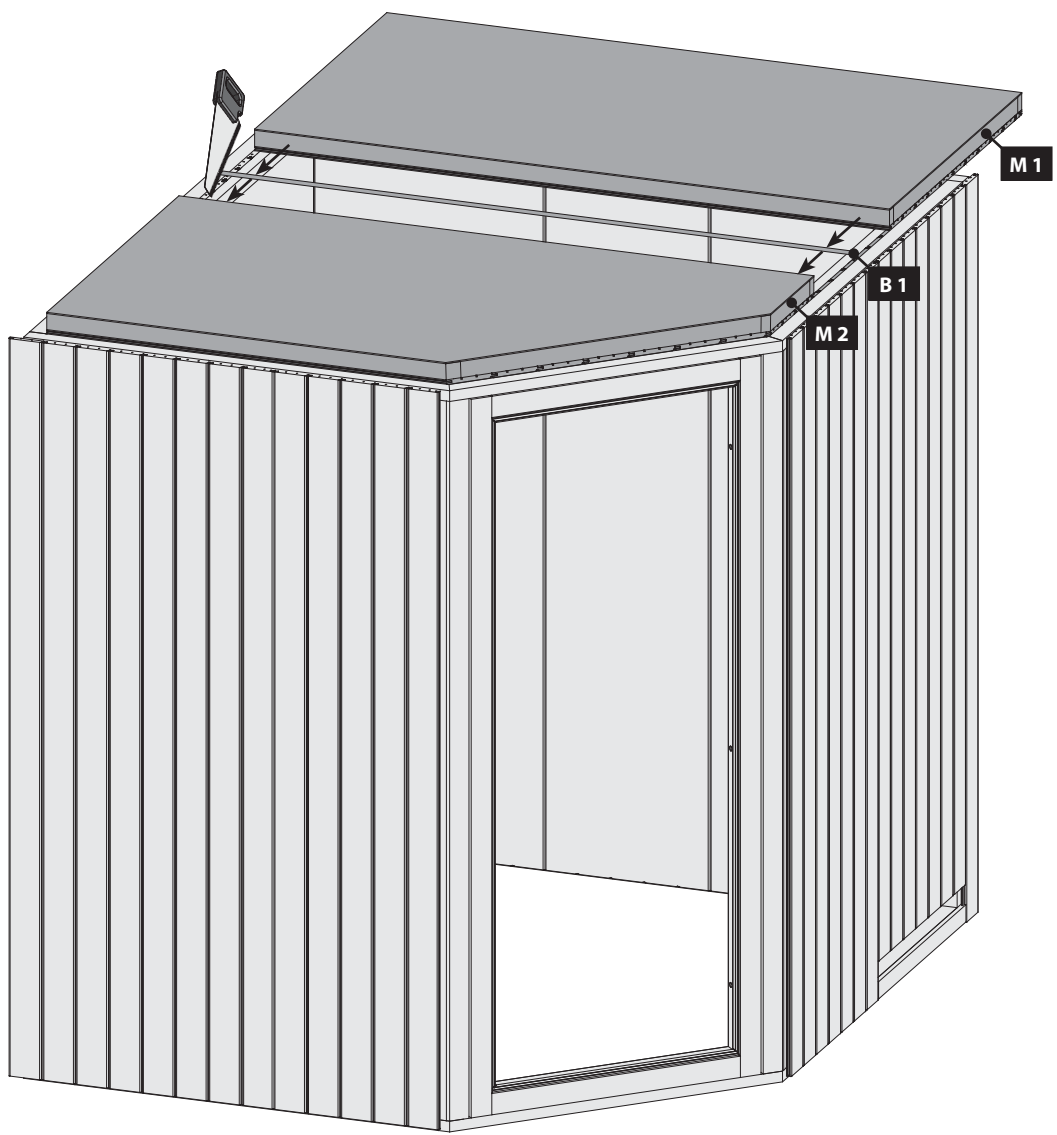

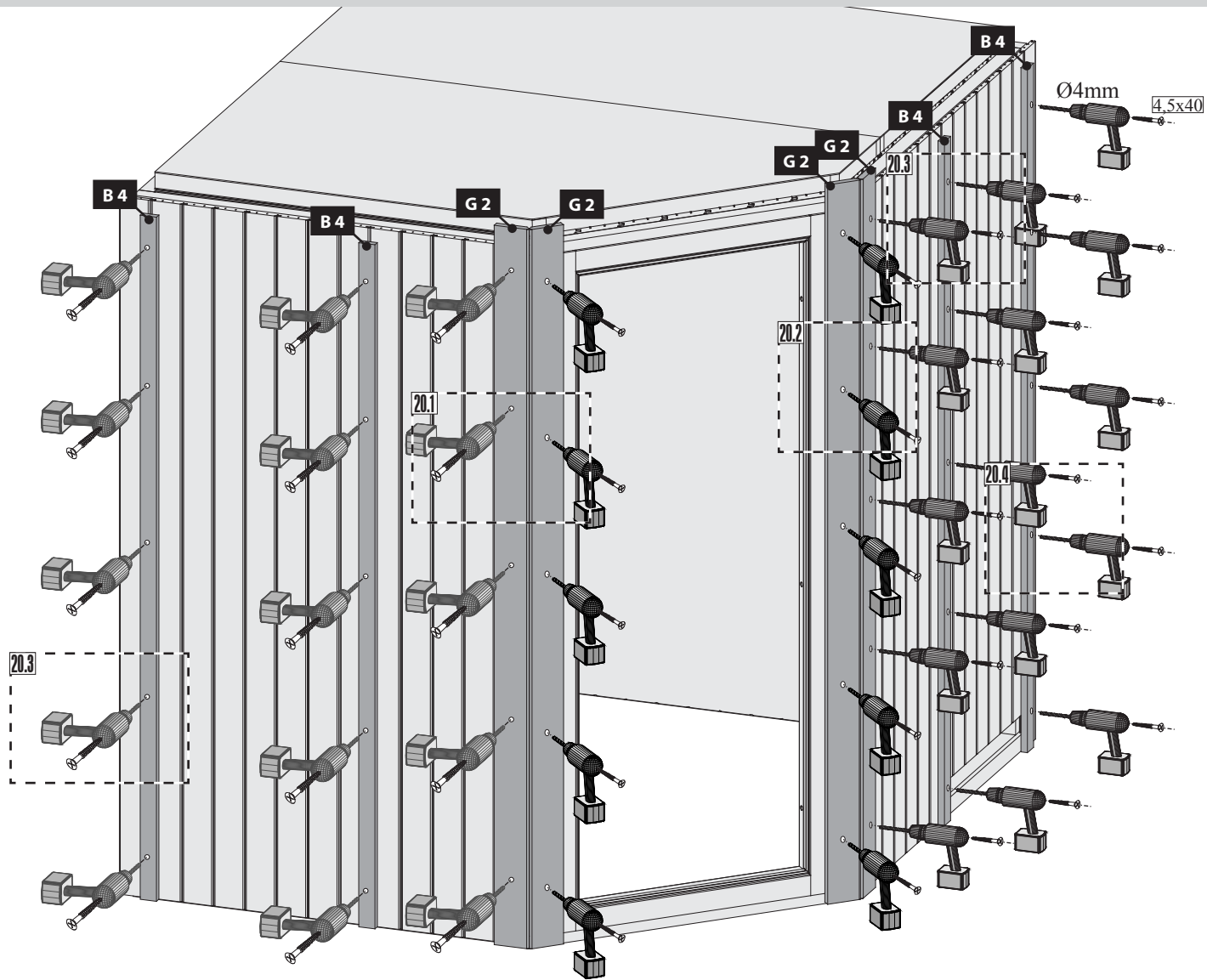

20.1

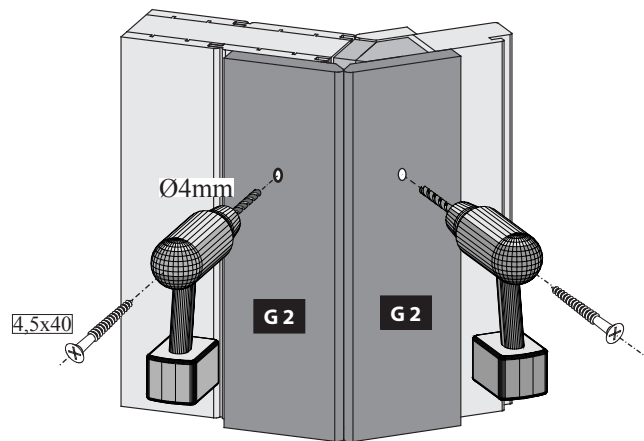

20.2

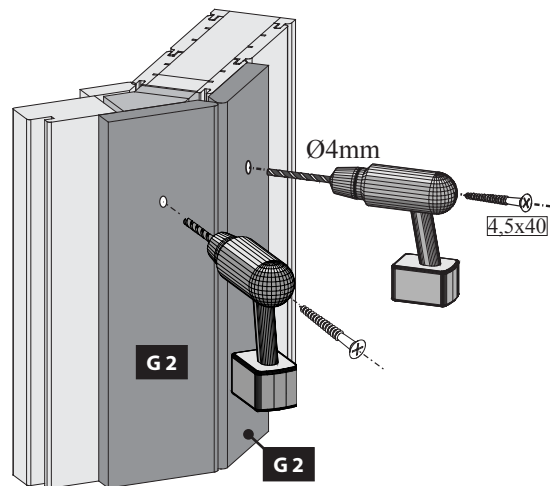

20.3

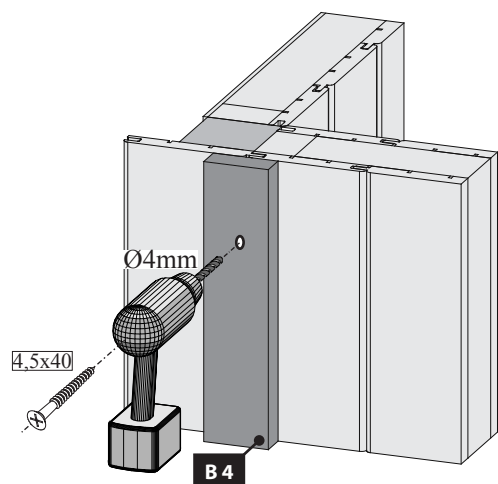

20.4

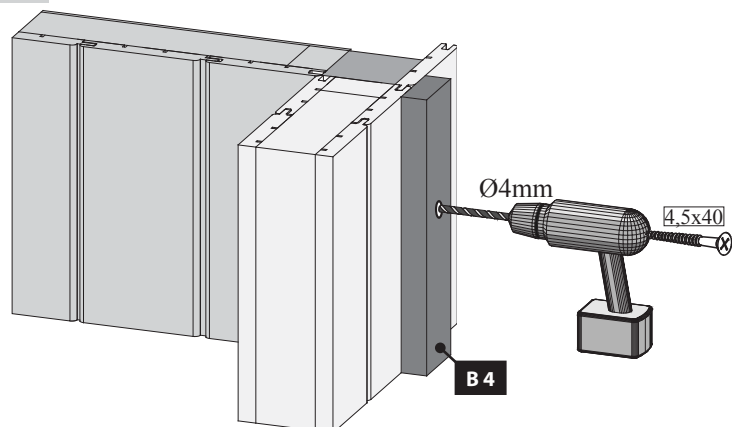

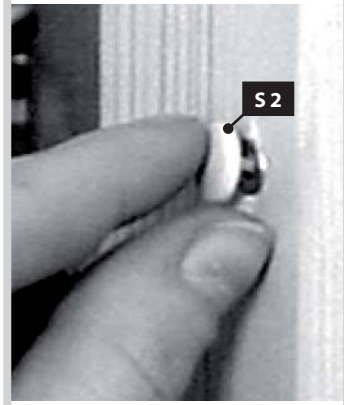
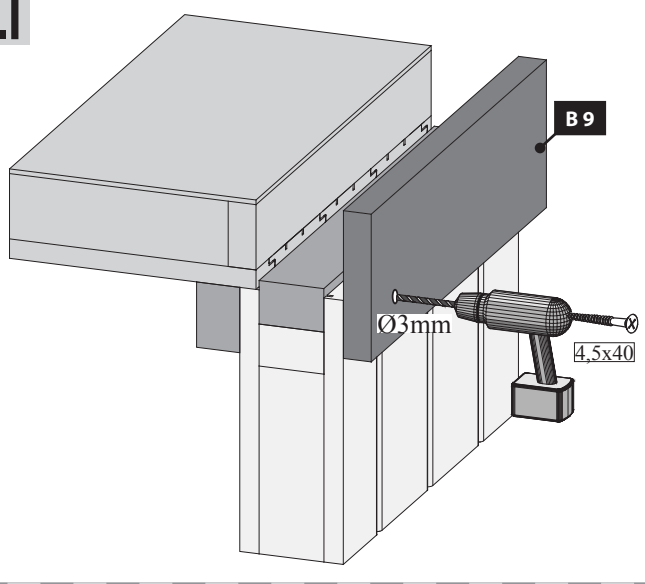
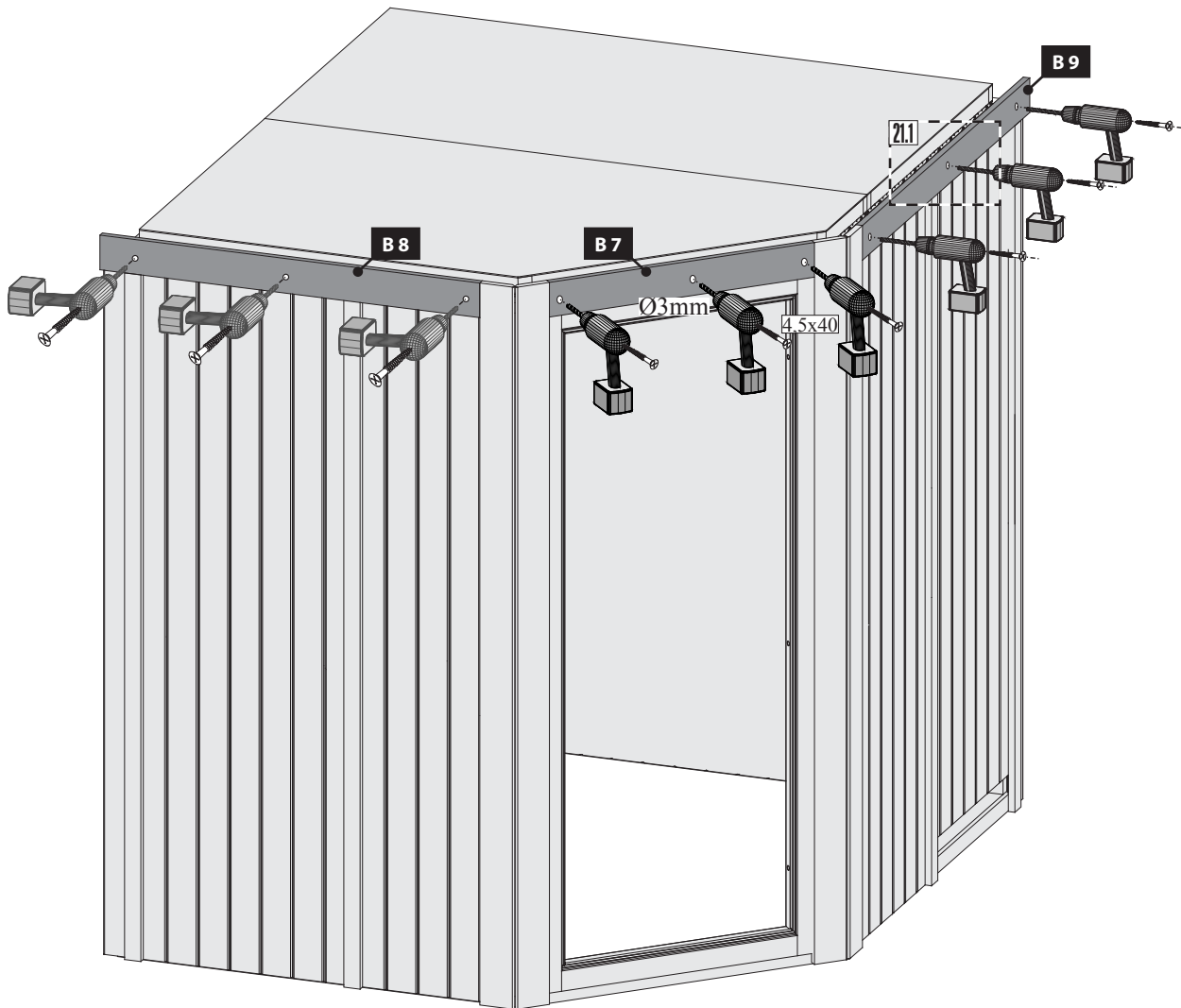

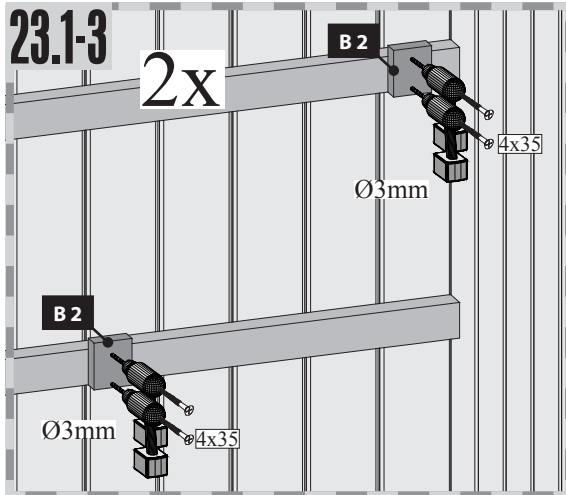
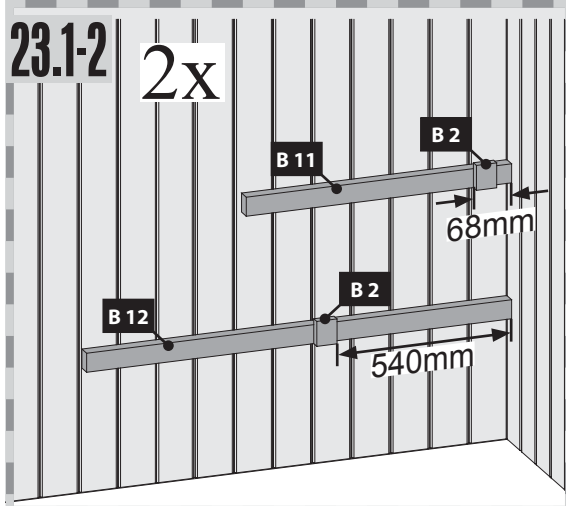
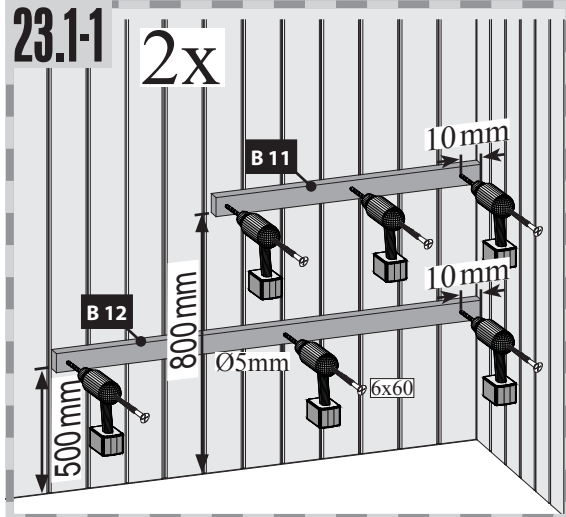
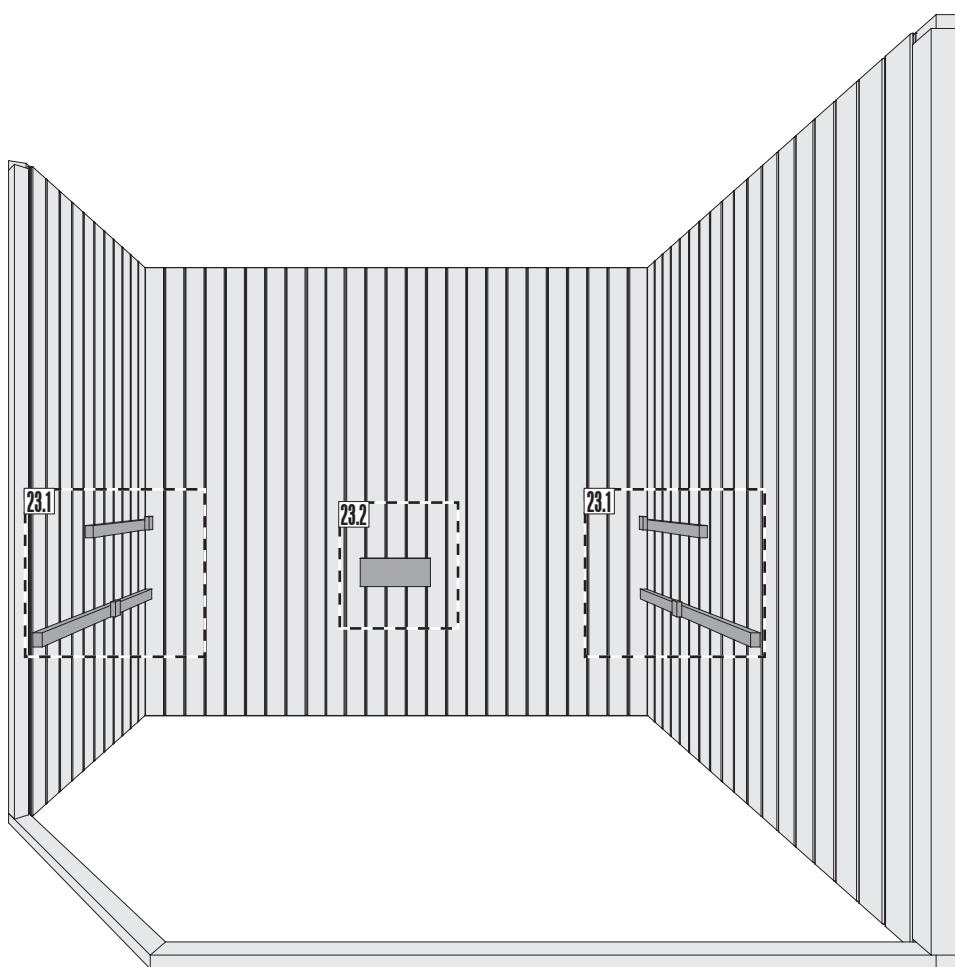

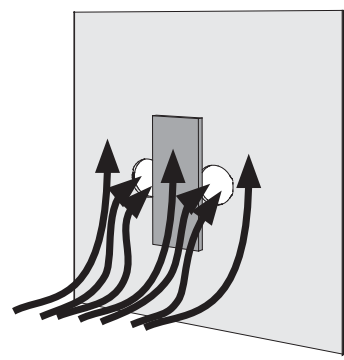
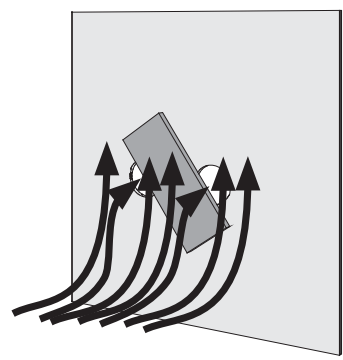
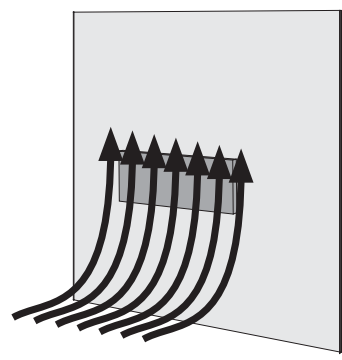
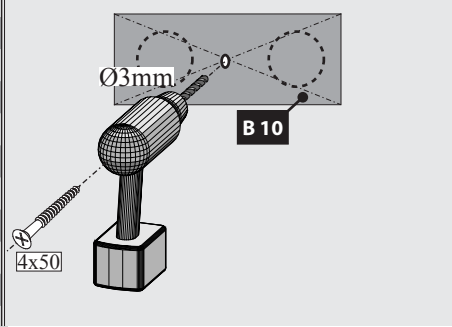

23.2



 Hier ist die Funktionsweise des Brettes abgebildet. Regeln Sie damit die Abluft nach Ihren eigenen Wünschen.

 Ceci représente le mode de fonctionnement de la planche. Avec elle, réglez l'écoulement de l'air selon vos désirs.

 This figure shows the functional principle of the board. Regulate the exhaust air according to your own wishes.

 Hier is de werking van het plankje afgebeeld. Regel daarmee de luchtafvoer naar eigen wens.

 Aquí está representada la forma de funcionamiento de la tabla. Regule con ello el aire de salida según sus propios deseos.

 Viene illustrato il principio di funzionamento della tavoletta di regolazione della ventilazione. Con essa si può regolare a piacere la ventilazione.

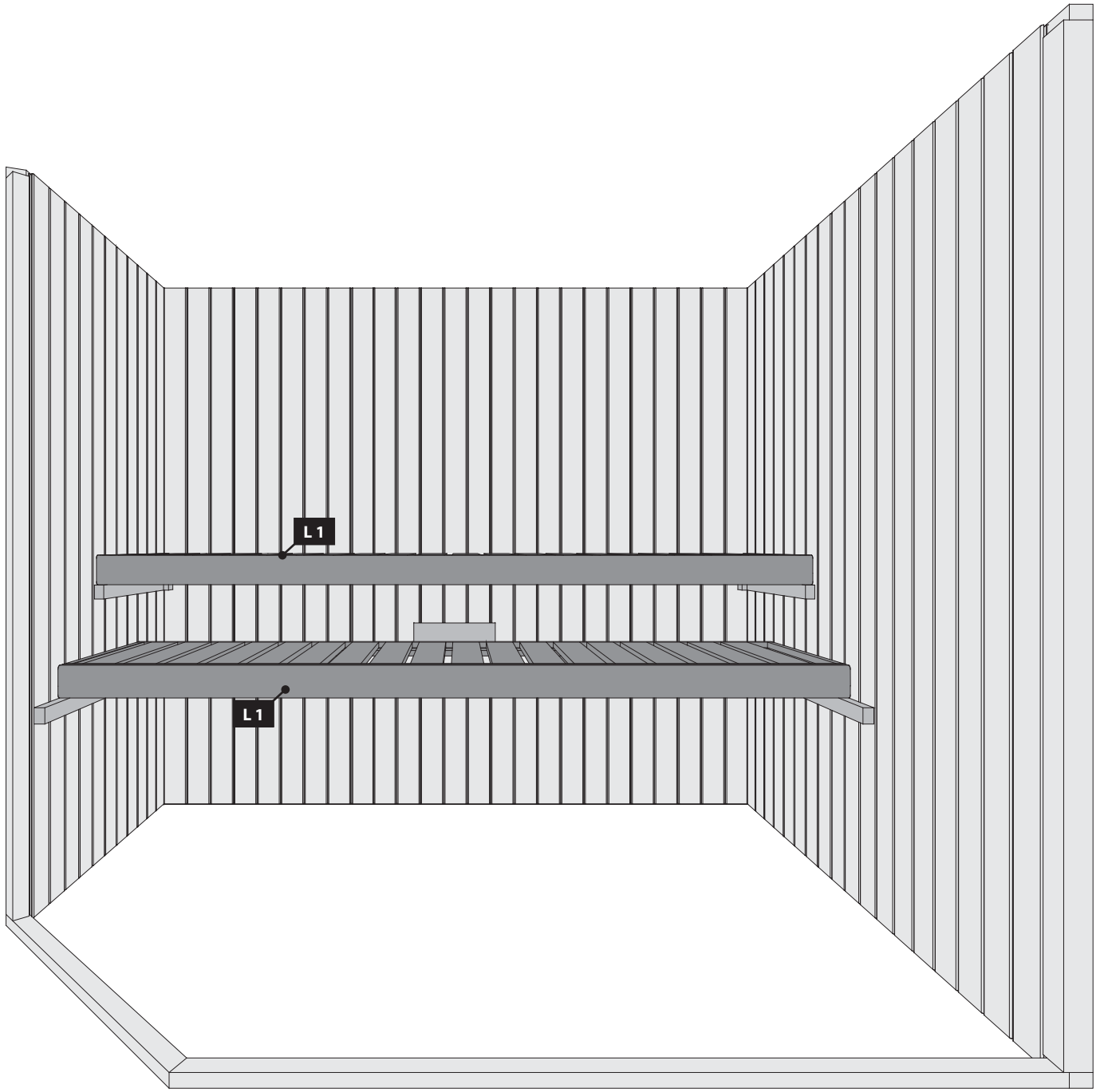

25 2x

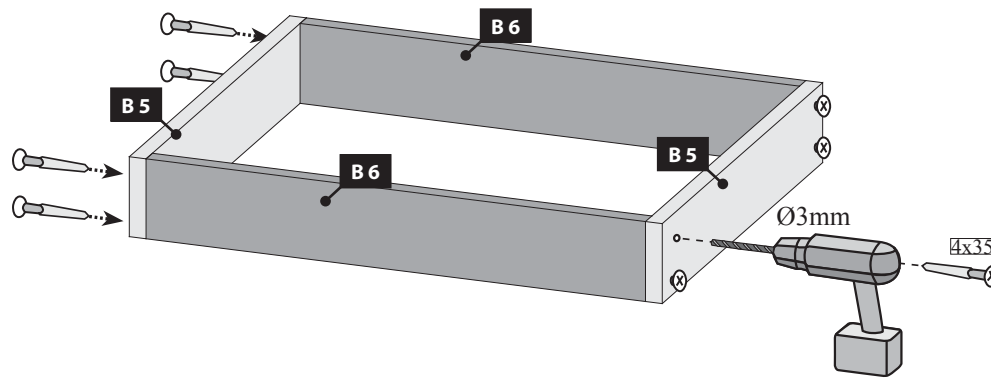

26 a

-  Nur bei 9 kW-Ofen
-  Seulement 9 kW chauffe
-  Only 9 kW heater
-  Slechts 9 kW heater
-  Sólo calentador de 9 kW
-  Solo riscaldamento 9 kW
-  Pouze topné těleso 9 kW

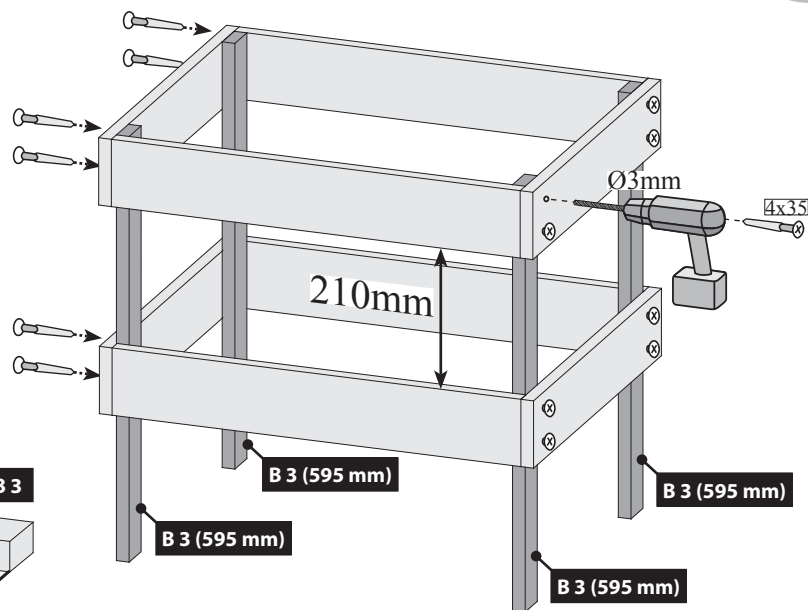
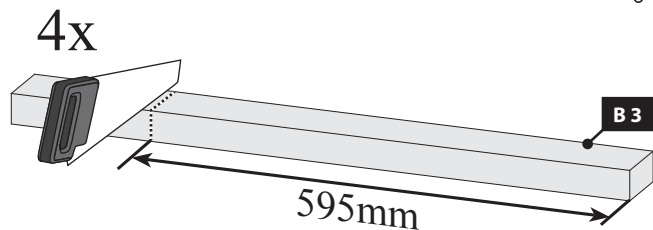

26 b

-  Bei allen anderen Öfen
-  Pour tous les autres fours
-  For all other furnaces
-  Voor alle andere ovens
-  Para todos los otros hornos
-  Per tutti gli altri tipi di forni
-  U všech ostatních pecích

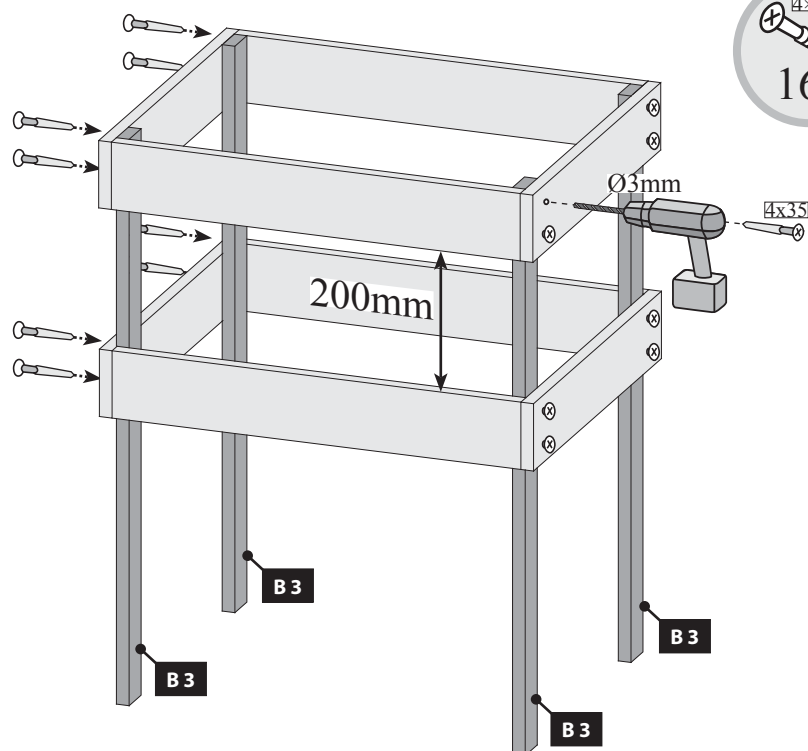

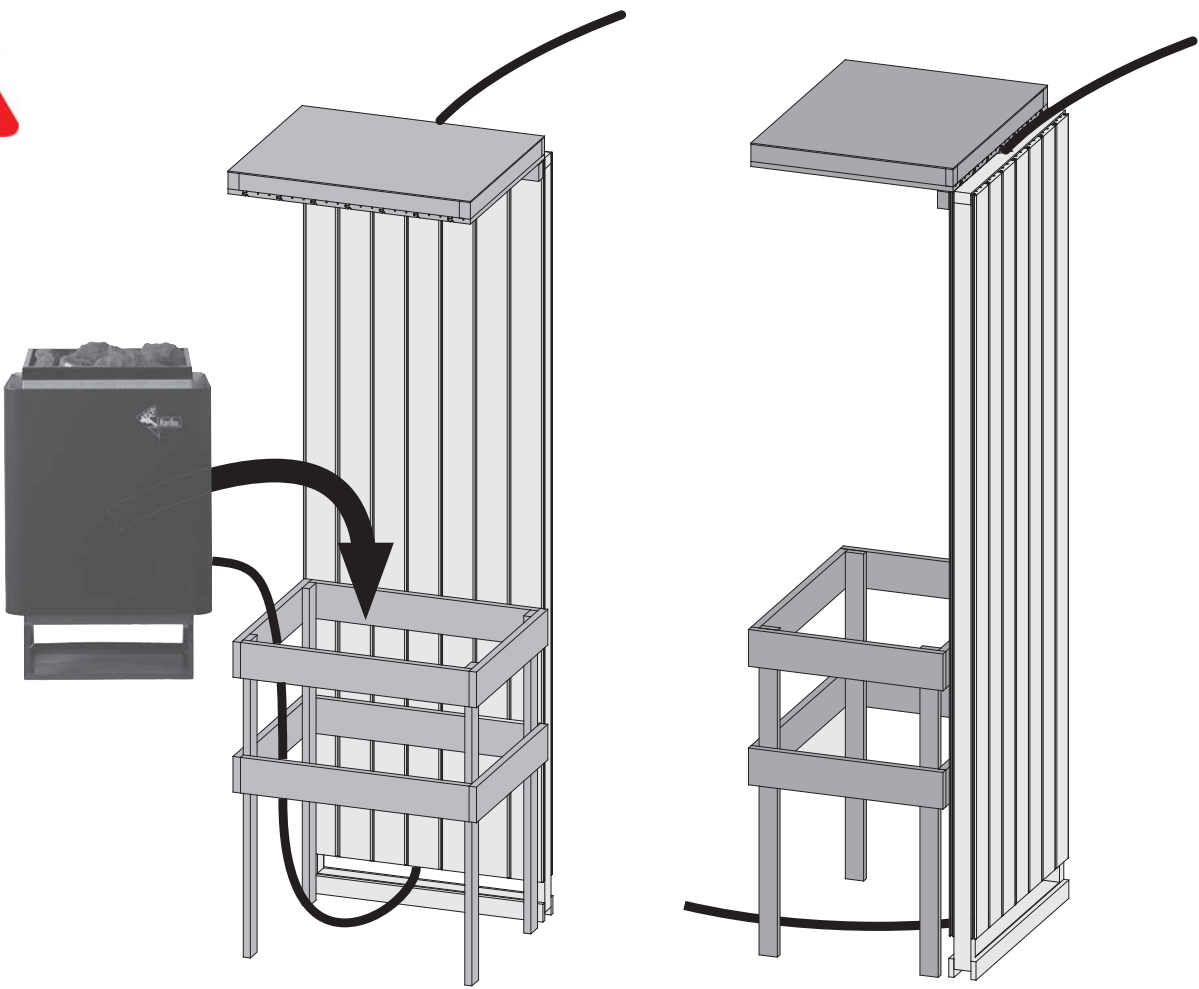



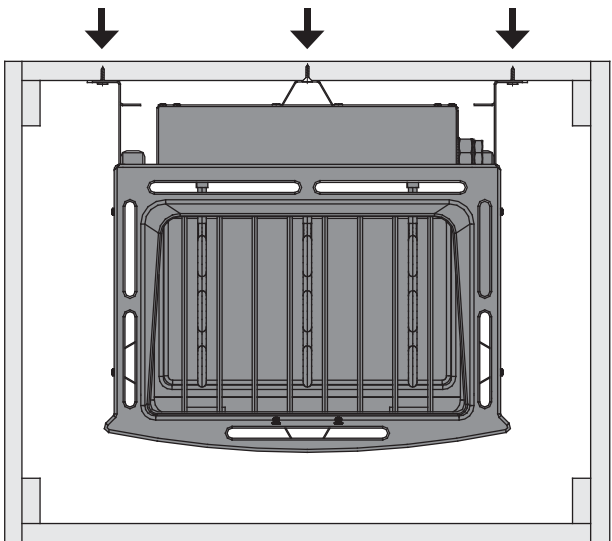
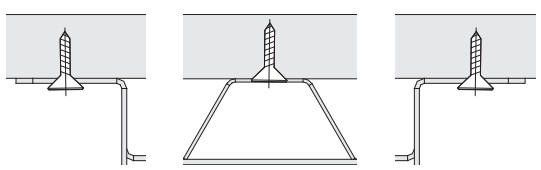



-  Ofenbefestigung
-  oven vaststelling
-  oven fixing
-  fixation four
-  fijación horno
-  fissaggio forno
-  upevňovací trouba



04 — 08



-  Einbau Glastür
-  Installation of glass door
-  Montage porte en verre
-  Montage van de glazen deur

-  Montaje de la puerta de cristal
-  Installazione portello di vetro
-  Namestitev steklena vrata



25551

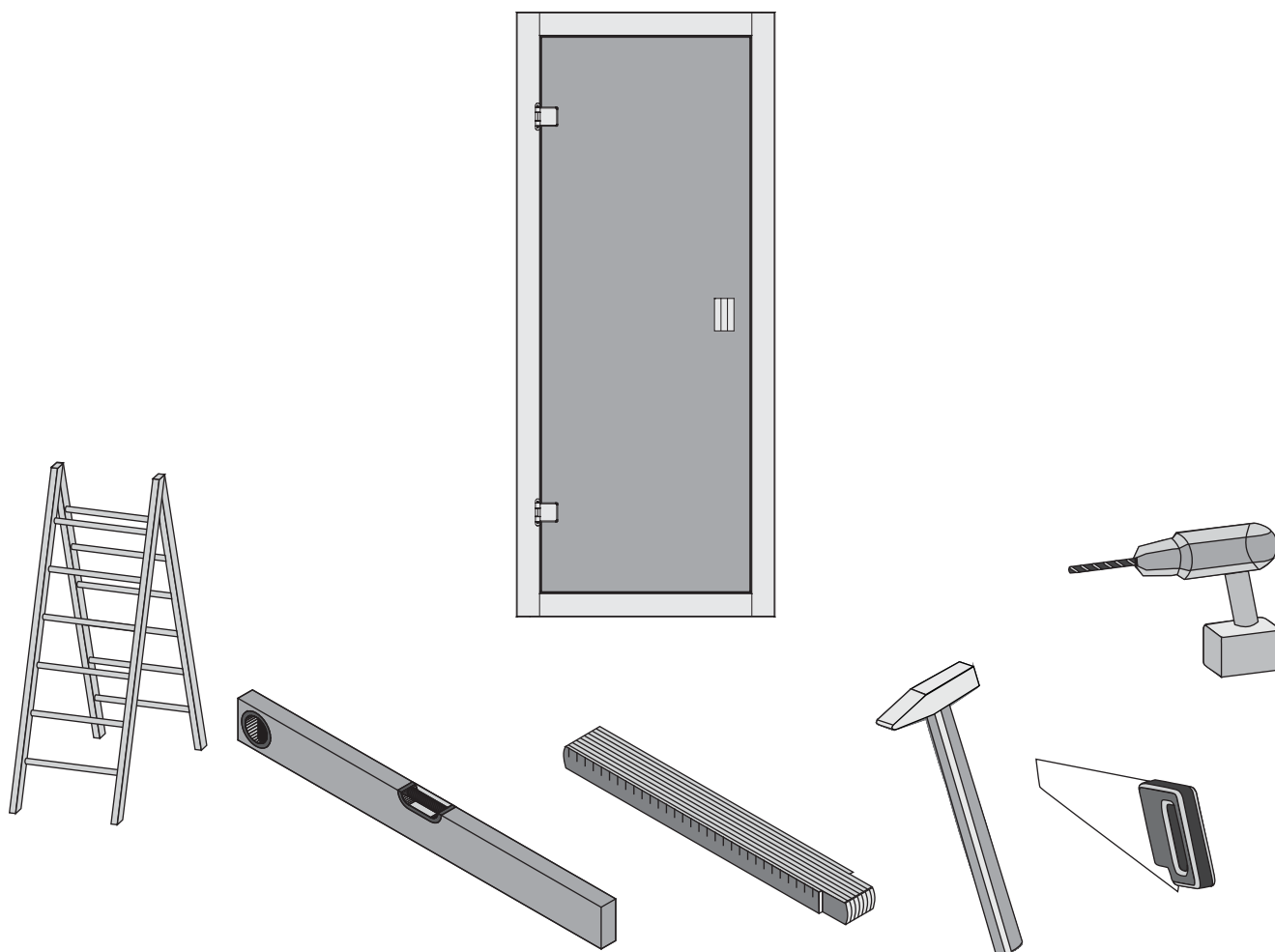

 **Aufbauanleitung**

 **Building Instructions**

 **notice de montage**

 **montagehandleiding**

 **Montagevejledning**

 **Instrucciones de construcción**

 **Istruzioni per il montaggio**

 **Montážní návod**



+49 421 38693 33



Vergleichen Sie zuerst die Material-liste mit Ihrem Paketinhalt! Bitte haben Sie Verständnis, dass Beanstandungen nur im nicht aufgebauten Zustand bearbeitet werden können!



Vergelijk eerst de lijst van materialen met de inhoud van uw pakket! Reclamaties kunnen alleen in behandeling worden genomen zolang de onderdelen nog niet zijn gemonteerd!



Confrontate questa distinta materiali prima con il contenuto del pacchetto! Vi preghiamo di comprendere che eventuali reclami possono essere accolti solo prima del montaggio!



First compare the list of materials with your package contents! Please understand that complaints can be processed in the non-built status only!



Start med at kontrollere materialelisten med indholdet af den leverede pakke! Vi gør venligst opmærksom på at reklamationer kun kan behandles for materialer som ikke er blevet bearbejdet!



Nejprve přezkontrolujte obsah balení podle materiálového listu! Mějte pochopení pro to, že případnou reklamaci se můžeme zabývat pouze tehdy, když díly nebudou smontované! Za pomoci tohoto seznamu můžete jednotlivé díly přiřadit k montážnímu návodu.



Commencez par comparer la liste du matériel avec le contenu de votre paquet! Sachez que nous traitons uniquement les réclamations concernant le matériel à l'état non monté!





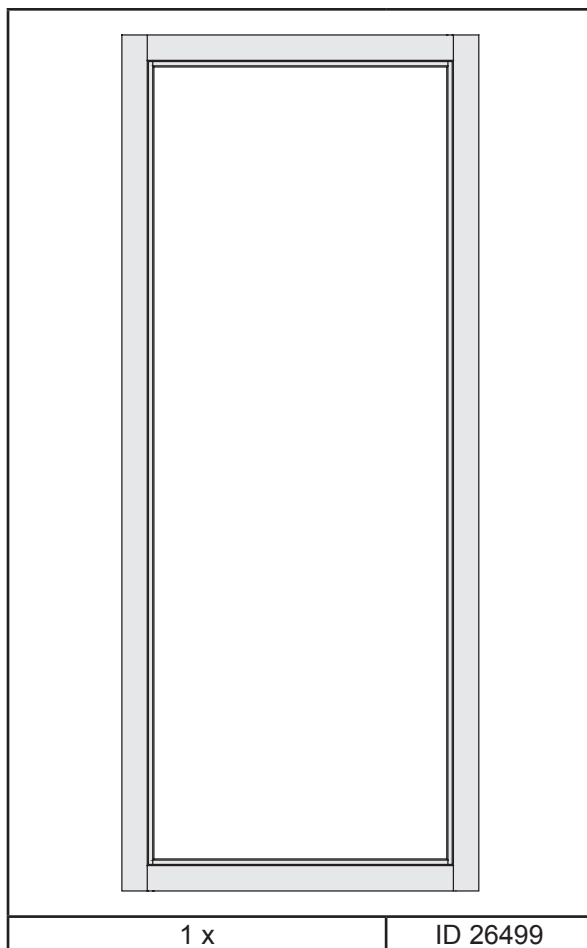
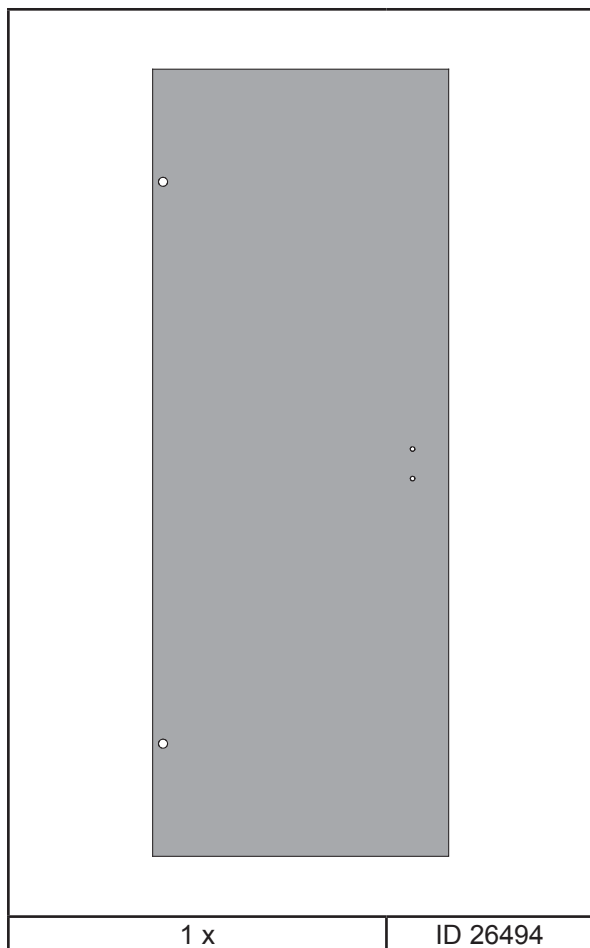
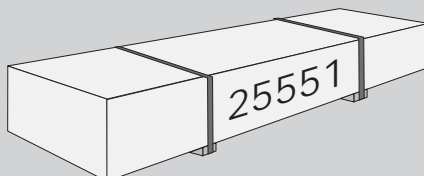





En primer lugar, compare la lista de material con el contenido del paquete. Rogamos entienda que las reclamaciones sólo pueden ser tramitadas antes de montar el objeto!



! Bitte beachten Sie, dass es sich bei einem Spontanbruch infolge von Nickelsulfideinschlüssen um Glasbrüche handelt, die nicht auf Verarbeitungsfehler basieren und somit nicht durch den Hersteller und dem Verarbeiter zu vertreten sind. Der Spontanbruch ist als hinzunehmendes Allgemeinrisiko anzusehen.

Bitte haben Sie Verständnis, dass wir eine Nachlieferung nur gegen Berechnung ausführen können.

-  Einbau Glastür
-  Installation of glass door
-  Montage porte en verre
-  Montage van de glazen deur

-  Installationsglasdør
-  Montaje de la puerta de cristal
-  Installazione portello di vetro
-  Sauna Instalace dveře

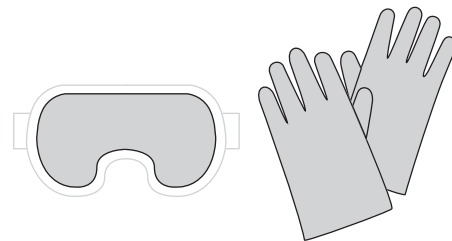

01



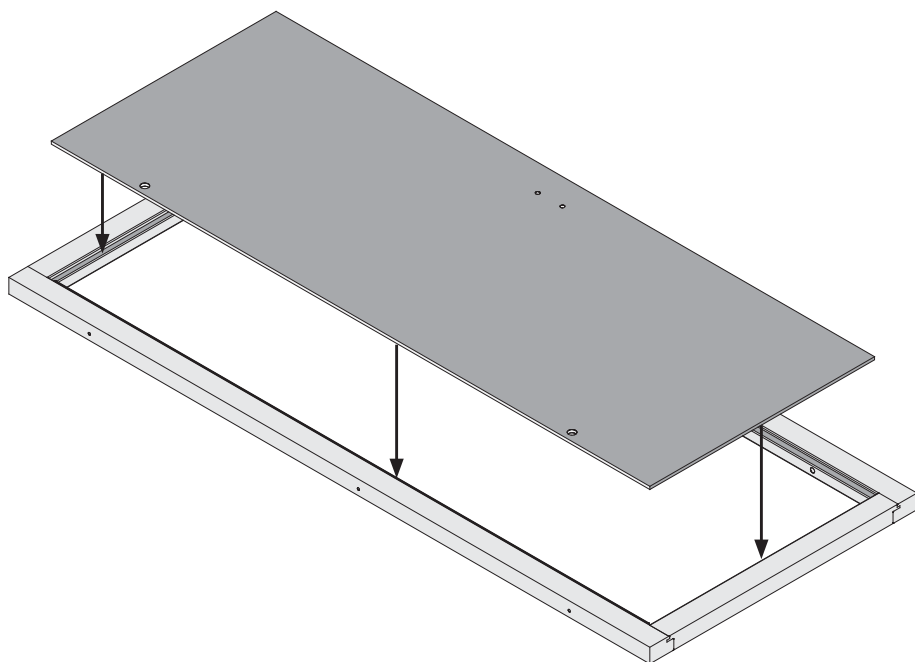

-  Saunätürglas in den Türrahmen legen
-  Put the door glass in the frame
-  Mettez le verre de la porte dans le cadre
-  Plaats het deurglas in het frame
-  Sæt dørglasset i rammen
-  Pon el vidrio de la puerta en el marco
-  Metti il vetro della porta nel telaio
-  Vložte sklo dveří do rámu



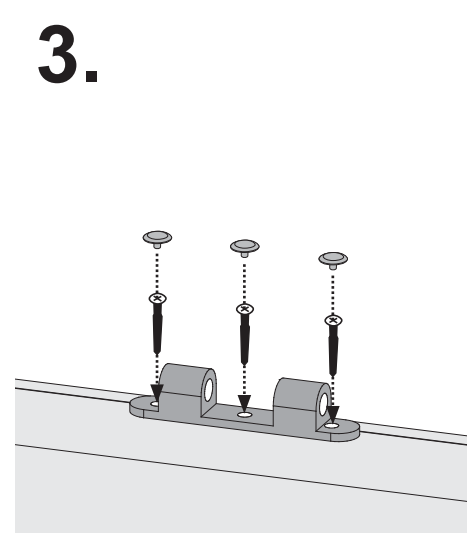
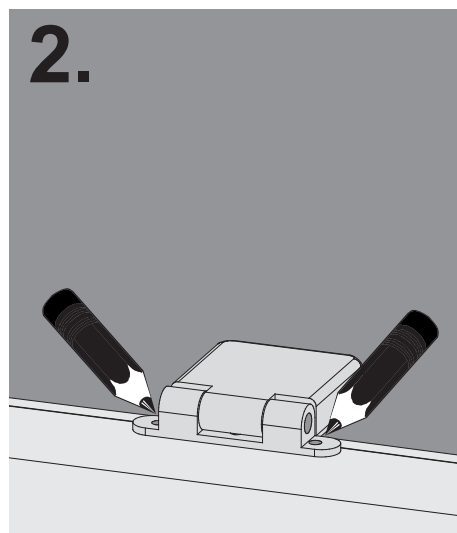
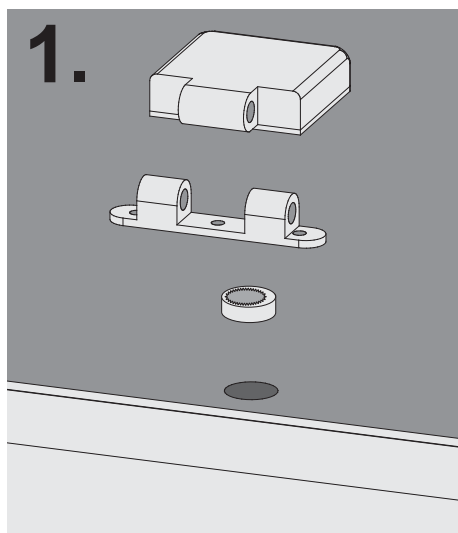
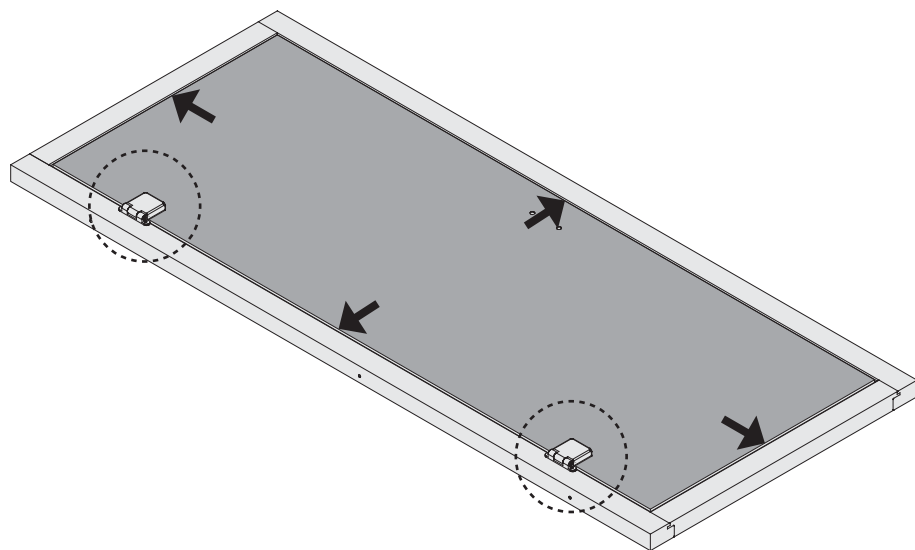



02

-  Saunätürglas in den Türrahmen ausrichten
-  Center the glass in the wooden frame
-  Bien aligner le verre à vitre
-  Lijn het glas uit in het deurframe
-  Juster saunaens dørglas i dørkarmen
-  Alinee el vidrio en el marco de la puerta
-  Allineare il vetro nel telaio della porta
-  Skleněná dvířka sauna v zárubně zarovnat



 Einbau Glastür
 Installation of glass door
 Montage porte en verre
 Montage van de glazen deur

 Installationsglasdør
 Montaje de la puerta de cristal
 Installazione portello di vetro
 Sauna Instalace dveře

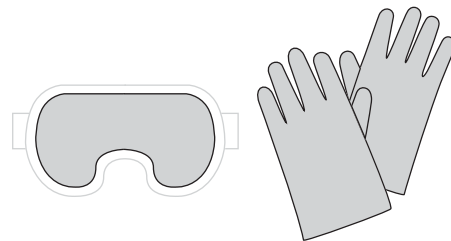

03

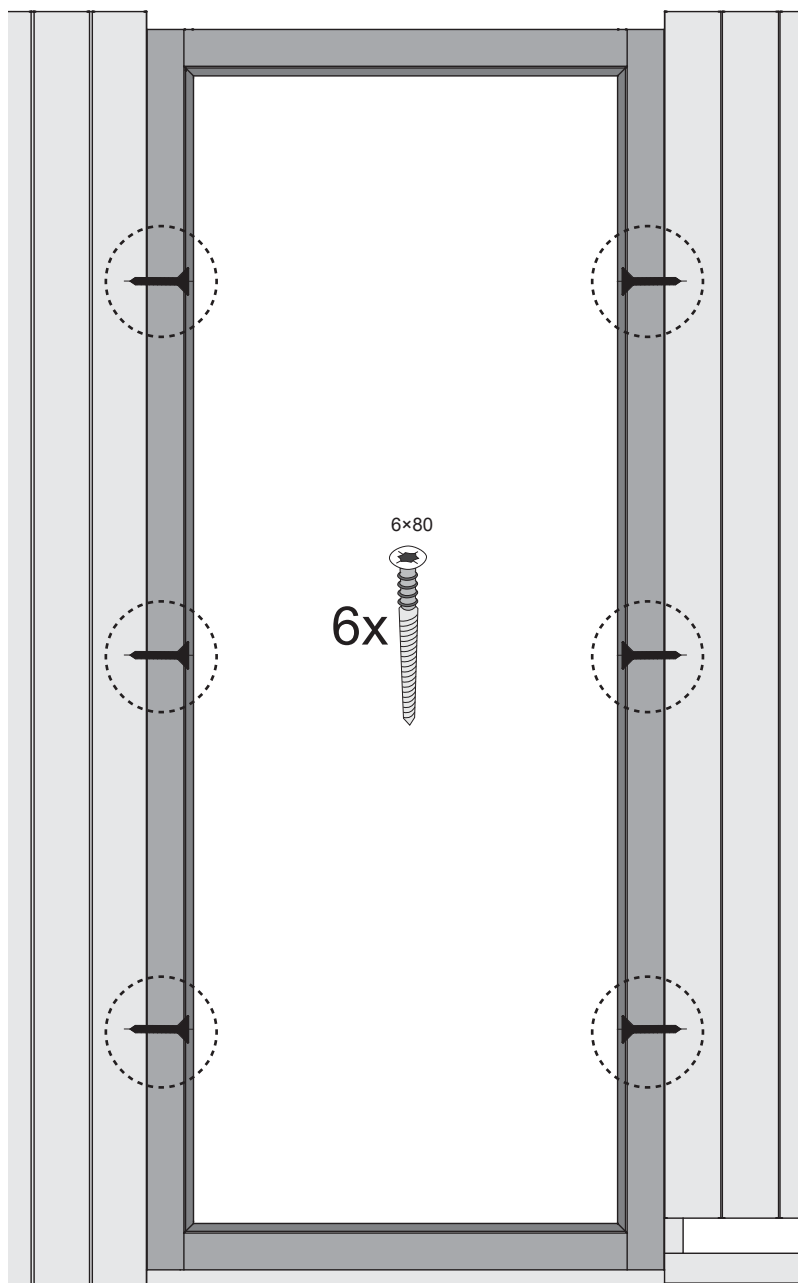
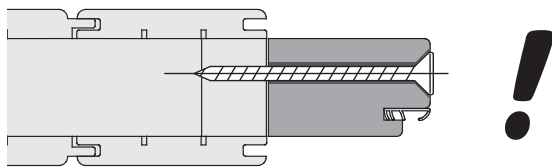



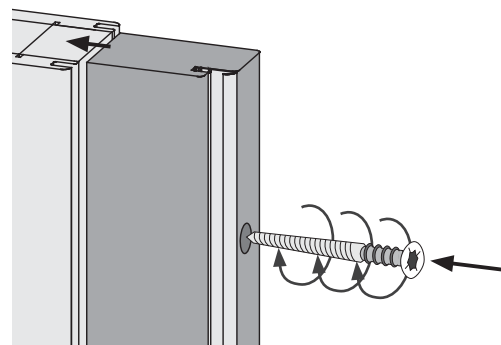



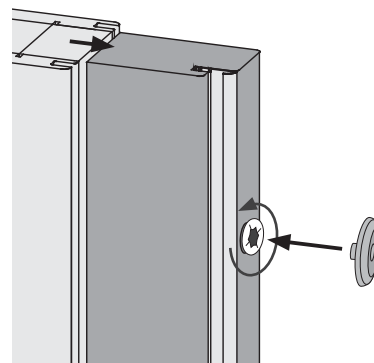

1.



2.



-  Einbau Glastür
-  Installation of glass door
-  Montage porte en verre
-  Montage van de glazen deur

-  Installationsglasdør
-  Montaje de la puerta de cristal
-  Installazione portello di vetro
-  Sauna Instalace dveře

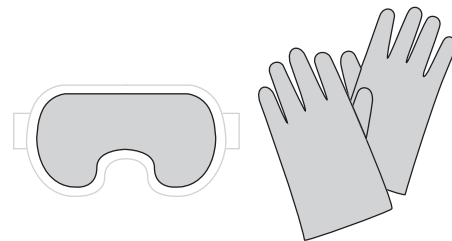

04

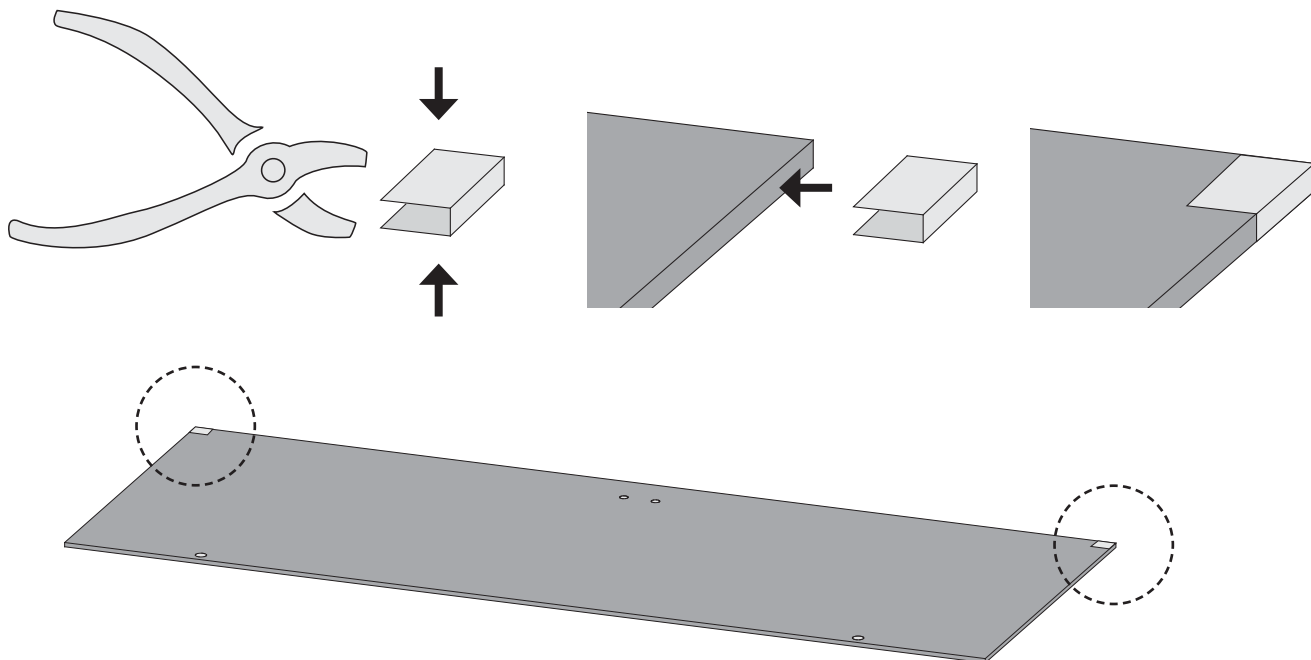



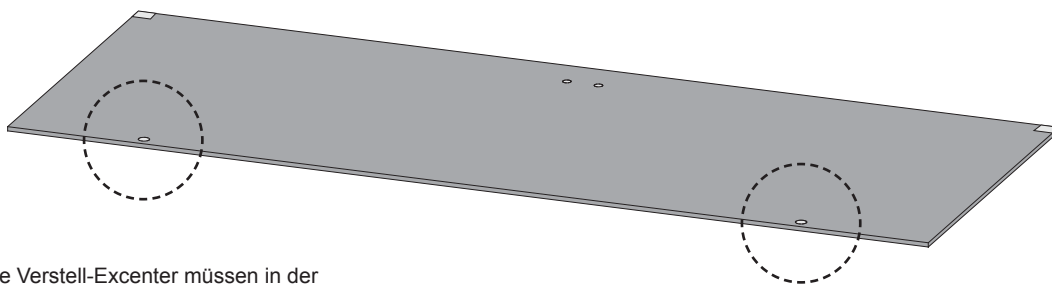



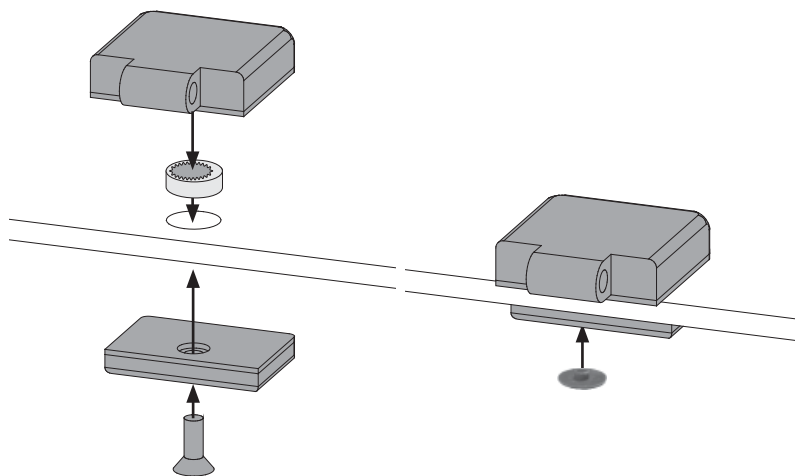

05



-  Alle Verstell-Excenter müssen in der Glasscheibe die gleiche Grundstellung haben
-  All adjustable eccentrics must have the same basic adjustment in the glass panel
-  Tous les excentreurs de positionnement doivent avoir la même position de base dans la vitre
-  Alle excentrische verstelelementen moeten in dezelfde stand in de glasplaat worden geplaatst
-  Alle justeringsexcenterer skal have samme grundlæggende position i glasruden
-  Todos los excéntricos regulables tienen que tener la misma posición base en la hoja de cristal
-  Tutti gli eccentrici di regolazione devono avere la stessa posizione base nella lastra di vetro
-  šechny nastavovací podivínů musí mít stejný základní polohy ve skle





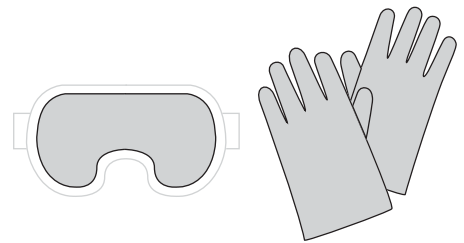

-  Einbau Glastür
-  Installation of glass door
-  Montage porte en verre
-  Montage van de glazen deur



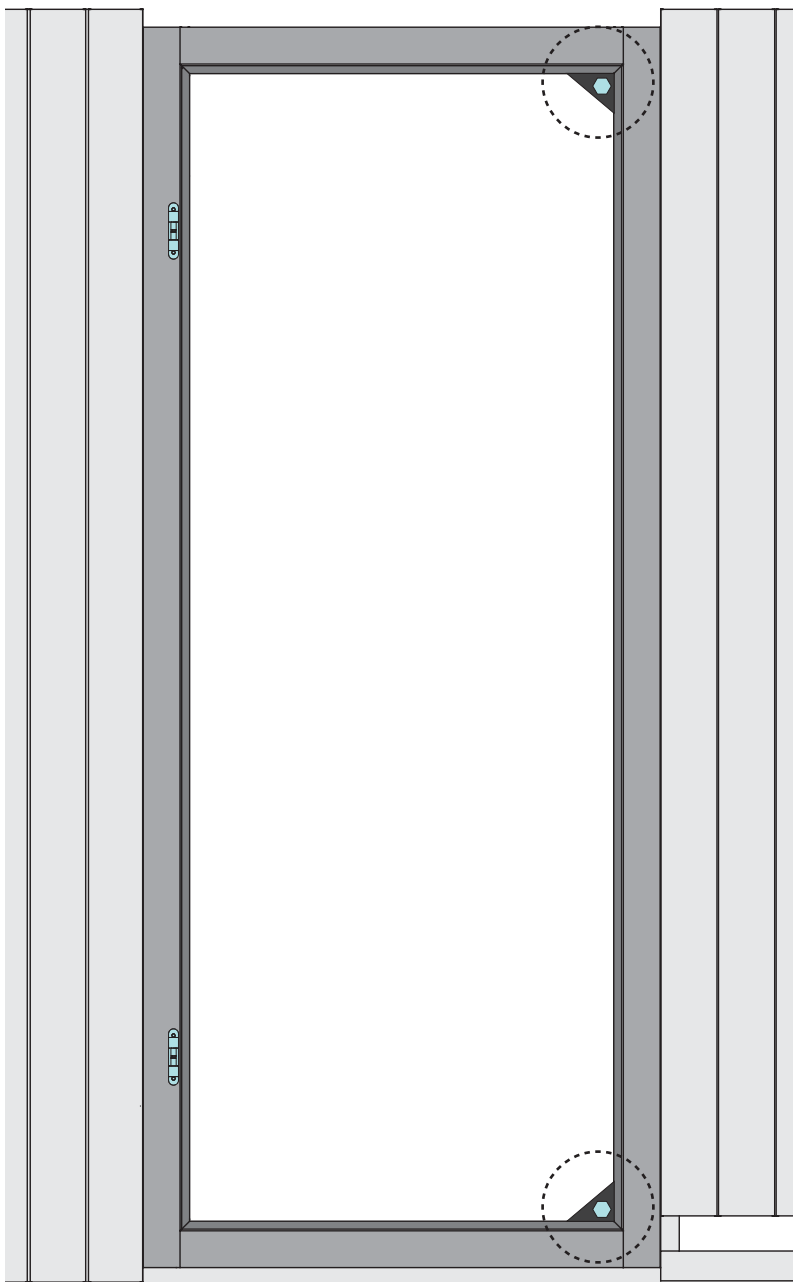

-  Installationsglasdør
-  Montaje de la puerta de cristal
-  Installazione portello di vetro
-  Sauna Instalace dveře



06







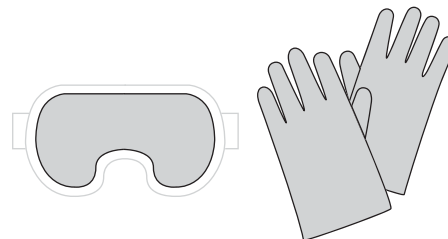



-  Einbau Glastür
-  Installation of glass door
-  Montage porte en verre
-  Montage van de glazen deur

-  Installationsglasdør
-  Montaje de la puerta de cristal
-  Installazione portello di vetro
-  Sauna Instalace dveře



07

-  Alle Verstell-Excenter müssen in der Glasscheibe die gleiche Grundstellung haben
-  All adjustable eccentrics must have the same basic adjustment in the glass panel
-  Tous les excentreurs de positionnement doivent avoir la même position de base dans la vitre
-  Alle excentrische verstelelementen moeten in dezelfde stand in de glasplaat worden geplaatst

-  Alle justeringsexcentricer skal have samme grundlæggende position i glasruden
-  Todos los excéntricos regulables tienen que tener la misma posición base en la hoja de cristal
-  Tutti gli eccentrici di regolazione devono avere la stessa posizione base nella lastra di vetro
-  Šechny nastavovací podivínů musí mít stejný základní polohy ve skle

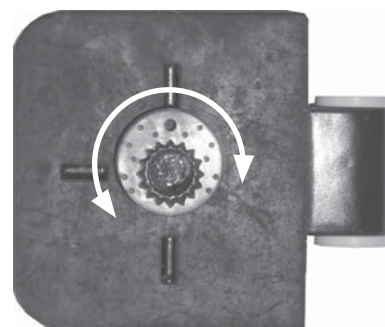
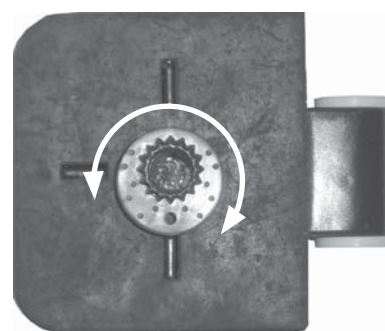
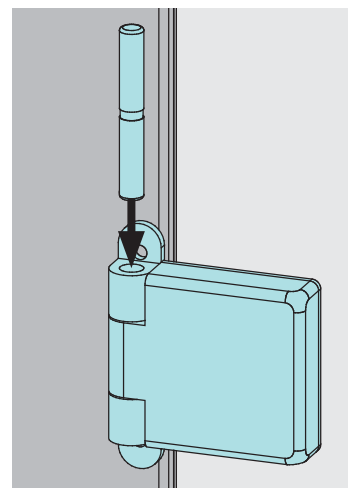
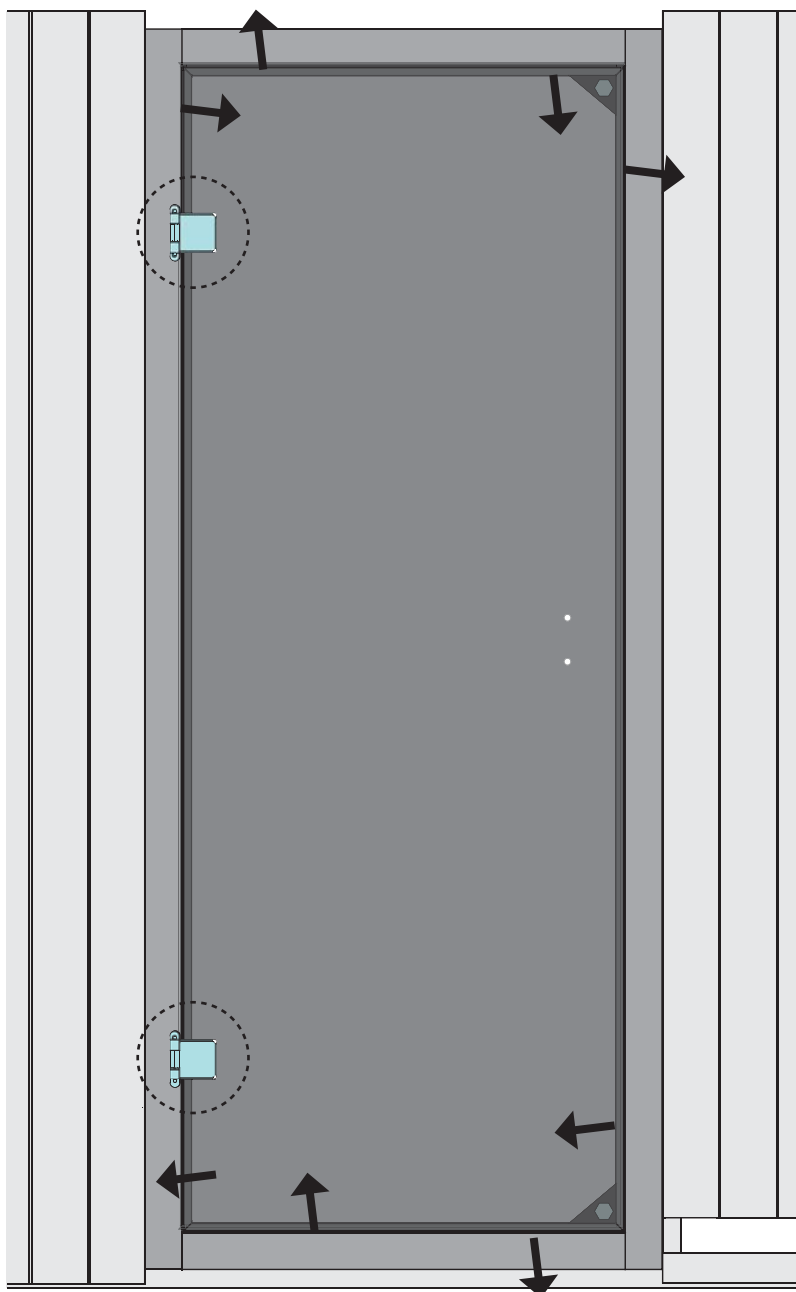

1.

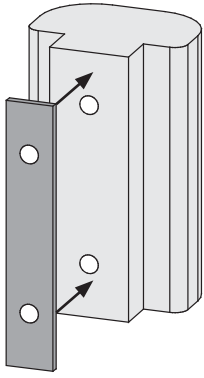

2.

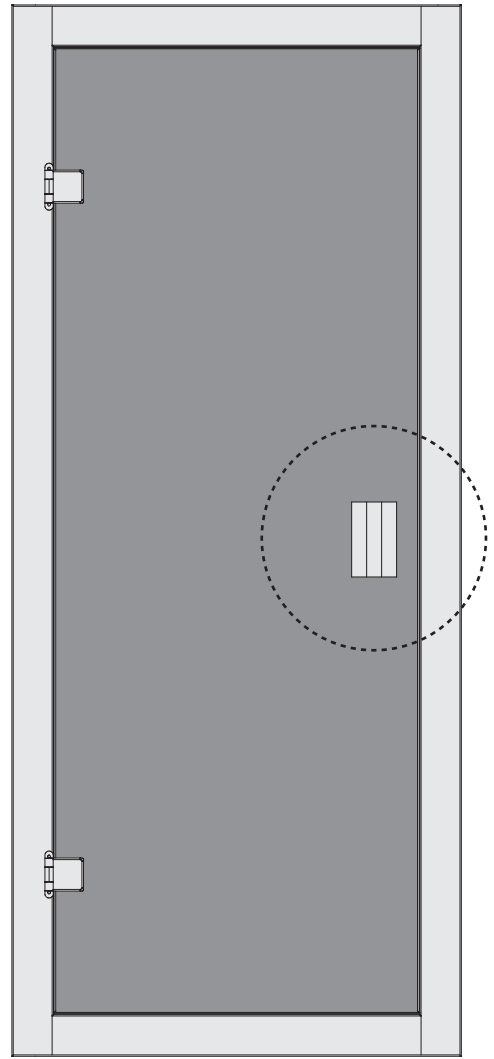
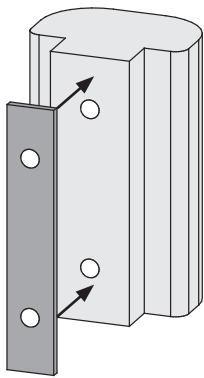

3.

